

**Audi 3.0l V6 TFSI engine
with Roots blower**

Self-Study Programme 437

For the first time, Audi has brought to market a mechanically supercharged powerplant: the 3.0l V6 TFSI. This Roots blower supercharged engine is based on the 3.2l V6 naturally aspirated engine from the current Audi V engine family.

By embracing new technology, in combination with the FSI combustion process, Audi has developed an engine concept that cuts an impressive figure in terms of its compact design, acoustics, responsiveness and fuel efficiency.

The engine has a broad range of characteristics from comfort-oriented to ultra-sporty. The sporty version of the engine specifically targets US clientele. The car's so-called take-off behaviour plays a key role here. The aim is to achieve the greatest possible acceleration between traffic lights in urban traffic.

With its enormous power, however, the 3.0l V6 TFSI engine is also well suited to comfort-oriented driving. A wide range of uses have been envisaged for it within the Audi product portfolio. In Europe, China and the USA, it will be available for the first time from the autumn of 2008 in the Audi A6.

Historically, mechanical supercharging using Roots blowers is nothing new to cars bearing the four-ring badge. In fact, Roots blowers were once used on the engines of the legendary AUTO UNION racing cars ("Silver Arrows"), which were powered by huge V engines with up to 16 cylinders supercharged by up to two Roots blowers. Between 1934 and 1939, the legendary AUTO UNION drivers spearheaded by Hans Stuck and Bernd Rosemeyer racked up numerous Grand Prix wins, not to mention setting a string of world speed records.



Audi 3.0I V6 TFSI engine



The objectives of this Self-Study Programme

In this Self-Study Programme you will learn about the design and operation of the 3.0I V6 TFSI engine. It provides you with all the information you need to describe the engine. Once you have worked your way through this Self-Study Programme, you will be able to answer the following questions:

- How is the engine designed mechanically?
- How does the cooling system work, and to what should attention be paid during servicing?
- How does the Roots blower based mechanical supercharging system work?
- What are the special features of the improved fuel system?
- How is the exhaust system configured?
- What are the new features of the engine management system?
- What do service employees need to know about the new engine?

Contents

Introduction

Brief technical description	6
---------------------------------------	---

Engine mechanicals

Cylinder block	10
Crank mechanism	11
Crankcase ventilation	12
Cylinder head	13
Driving the ancillary units/components.	14

Oil supply

Oil circulation system	15
----------------------------------	----

Air supply

Air circulation system	16
Supercharger module	20
Load management.	31
Intake manifold flaps.	32
Soundproofing	34

Cooling system

Cooling circuit.	36
Charge air cooling (intercooling).	38

Exhaust emissions treatment

Secondary air system	42
--------------------------------	----

Fuel system

Overview46
 Injectors47

Engine management

System overview48
 Engine control unit50

Service

Maintenance work51
 Special tools52

Annex

Glossary53
 Test yourself54

Summary

Self-Study Programmes55

Reference



Terms shown in italics and marked by an asterisk (*) are explained in the glossary at the end of this Self-Study Programme.

The Self-Study Programme teaches the design and function of new vehicle models, new automotive components or new technologies.

The Self Study Programme is not a Repair Manual. All values given are intended for reference purposes only and refer to the software version valid at the time of preparation of the SSP.

For information about maintenance and repair work, always refer to the current technical literature. Terms written in italics or indicated by an asterisk (*) are explained in the glossary at the back of this Self-Study Programme.

Reference

Note

Introduction

Brief technical description

The description of the 3.0l V6 TFSI engine refers to the Audi A6 of model year 2009. The engine-transmission unit is used for the first time on this model.

Here are the main technical features at a glance:

- Six-cylinder V engine with mechanical supercharging (technical basis: 3.2l V6 FSI engine)
- Fuel supply, activated carbon filter system, exhaust system (manifold for selective lambda control) and engine cooling system are identical to those of the 3.2l V6 FSI engine in terms of their geometry and position.
- Vacuum system with mechanical vacuum pump (identical to that of the 3.2l V6 FSI engine)

Here are the main changes over the 3.2l V6 FSI engine:

- Heat treated cylinder crankcase
- Crankshaft drive
- Supercharger module with integrated inter-cooling system
- Water pipes in the car's low-temperature circuit
- Belt drive for driving the supercharger module
- Engine management system with "Simos 8" p/n control
- Secondary air system for compliance with the EU V and ULEV II exhaust emission standards

The following have been adapted:

- Intake system
- Camshafts
- Valves and valve springs
- Flange for the tumble flaps

The following have been deleted:

- Audi valvelift system
- Exhaust camshaft adjustment

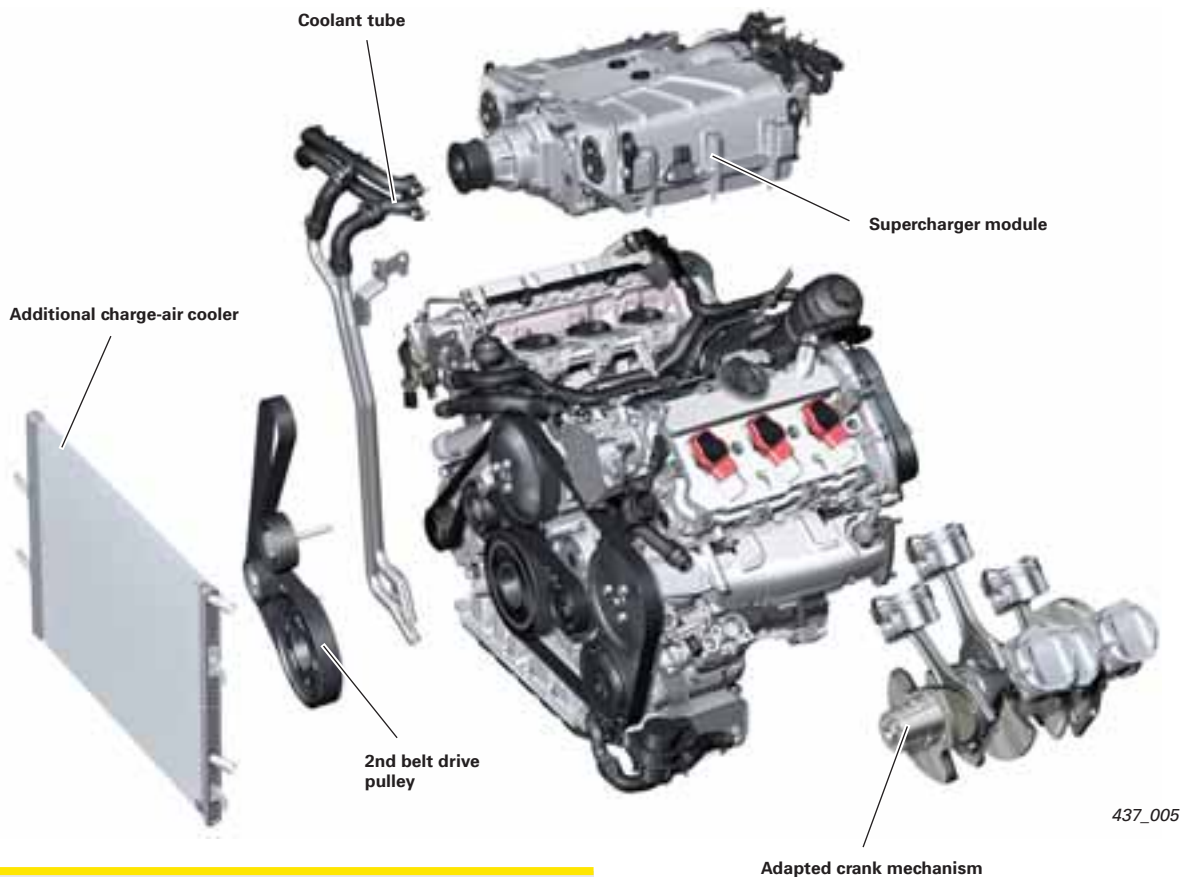

437_005

Reference

For a detailed technical description of the basic engine (3.2l V6 FSI engine), please refer to Self-Study Programme 411 "Audi 2.8l and 3.2l FSI engine with Audi valvelift system".



Torque/power curve

- Max. torque in Nm
- Max. power in kW

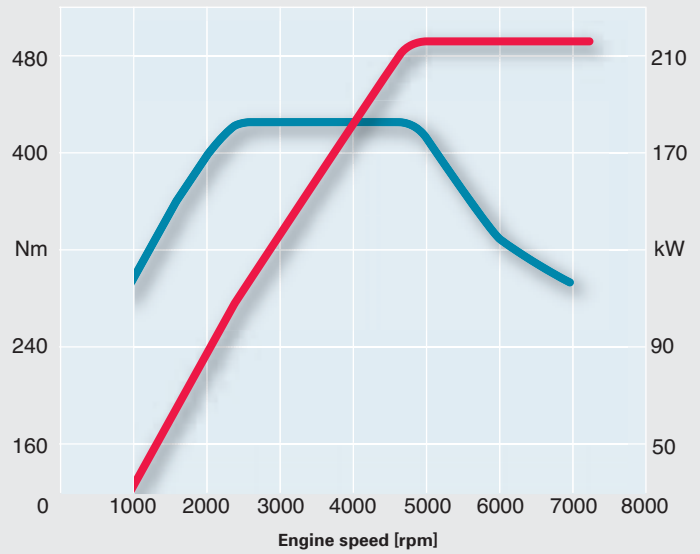

Specifications

Engine code	CAJA
Engine type	Six-cylinder V-engine
Displacement in cm³	2995
Max. power in kW (bhp)	213 (290) at 4850 – 7000 rpm
Max. torque in Nm	420 at 2500 – 4850 rpm
Valves per cylinder	4
Bore in mm	84.5
Stroke in mm	89
Compression ratio	10.5 : 1
Firing order	1–4–3–6–2–5
Engine weight in kg	190
Engine management	Simos 8
Fuel grade	95 RON*
Mixture formation	Direct injection FSI (homogeneous) High-pressure fuel pump HDP 3
Exhaust emission standard	EU V, ULEV II
Exhaust aftertreatment	Cylinder-selective lambda control with one broadband pre-cat sensor per cylinder bank, two ceramic catalytic converters with post-cat oxygen sensor (nonlinear sensor)
CO₂ emissions in g/km	228

* 91 RON unleaded petrol can also be used with a slight reduction in performance

Introduction

Characterisation

Although the 3.0l V6 TFSI engine does not have the largest displacement of the Audi V6 engine family, it sets the benchmark for power output.

This is also reflected in its performance, where the engine outstrips the equivalent naturally aspirated 3.2l V6 FSI unit.

The same goes for economy, i.e. fuel consumption and pollutant emissions. In the figure, you are shown a comparison of the full-throttle curves of the V6 FSI engines installed on the Audi A6.

Torque/power curves of the V6 FSI engines

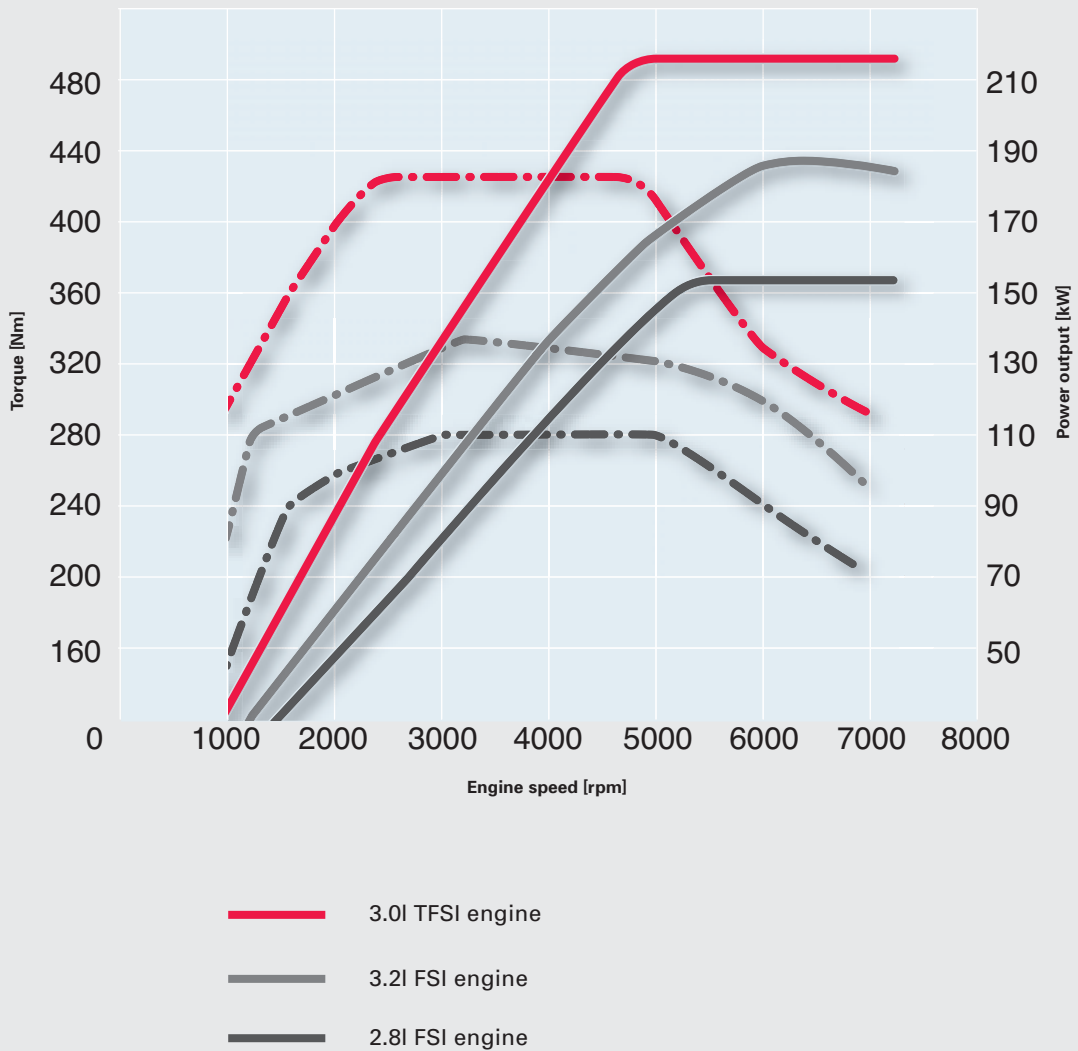

Specifications of the V6 engines on the Audi A6

Parameter	2.4I MPI	2.8I FSI	3.2I FSI	3.0I TFSI
Displacement in cm ³	2393	2773	3123	2995
Stroke in mm	77,4	82.4	92.8	89
Bore in mm	81	84.5	84.5	84.5
Stroke/bore	0.96	0.98	1.10	1.05
Compression ratio	10.3 : 1	12.0 : 1	12.5 : 1	10.5 : 1
Cylinder spacing in mm	90	90	90	90
Cyl. bank offset in mm	18.5	18.5	18.5	18.5
Main bearing diameter in mm	58	58	65	65
Big-end bearing diameter in mm	50	54	56	56
Con-rod length in mm	159	159	154	153
Engine block height in mm	228	228	228	228
Max. power in kW at rpm	130 at 6000	154 at 5250	188 at 6500	213 at 4800 – 7000
Max. torque in kW at rpm	230 at 3000	280 at 3000 – 5000	330 at 3250	420 at 2500 – 4850
Fuel in RON	95/91 ¹⁾	95/91 ¹⁾	95/91 ¹⁾	95/91 ¹⁾

¹⁾ with reduced power output

Comparison of performance data: 3.2I V6 FSI engine and 3.0I V6 TFSI engine on the Audi A6

		Audi A6 3.2I FSI 188 kW/330 Nm tiptronic quattro Model year 2008	Audi A6 3.0I TFSI 213 kW/420 Nm tiptronic quattro Model year 2009
Parameter	Units		
0 – 100 kph	S	7.1	6.3
Elasticity in speed D	kph	80 – 120	80 – 120
	S	6.0	5.3
Max. speed	kph	250 ²⁾	250 ²⁾
	rpm / gear	6350 / 5	4500 / 6
Average consumption (overall)	l/100 km	10.9	9.6
CO₂ emissions	g/km	259	228

²⁾ governed

Engine mechanicals

Cylinder block

The cylinder block is identical to that of the 3.2l V6 FSI engine. However, the load on the engine is higher due to the increased mean peak pressure (combustion pressure).

To nevertheless ensure high stability, the bearing seats undergo a special heat treatment process during manufacture. Also, higher strength main bearing bolts are used.

Cylinder block



Cylinder crankcase
bottom section (bedplate)



Oil pan top section



Oil pan bottom section



437_007

Crankshaft drive

Crankshaft

The crankshaft has been adapted for a stroke of 89 mm. Like the 3.2l V6 FSI engine, the crankshaft has a *split-pin configuration** (see glossary).

The newly developed, *cracked con-rods** are 153 mm long and optimised for strength. All bearing bushes are designed as lead-free 3-component composite bearing bushes.



437_008

Pistons

Unlike the 3.2l V6 FSI engine, the pistons, as ring carrier pistons, are rated for a compression ratio of 10.5:1.

The piston skirts therefore have a wear resistant Ferrostan plating. The special piston ring combination provides high power output and low blow-by gas flow rates, as well as low oil consumption in conjunction with minimum friction and wear.

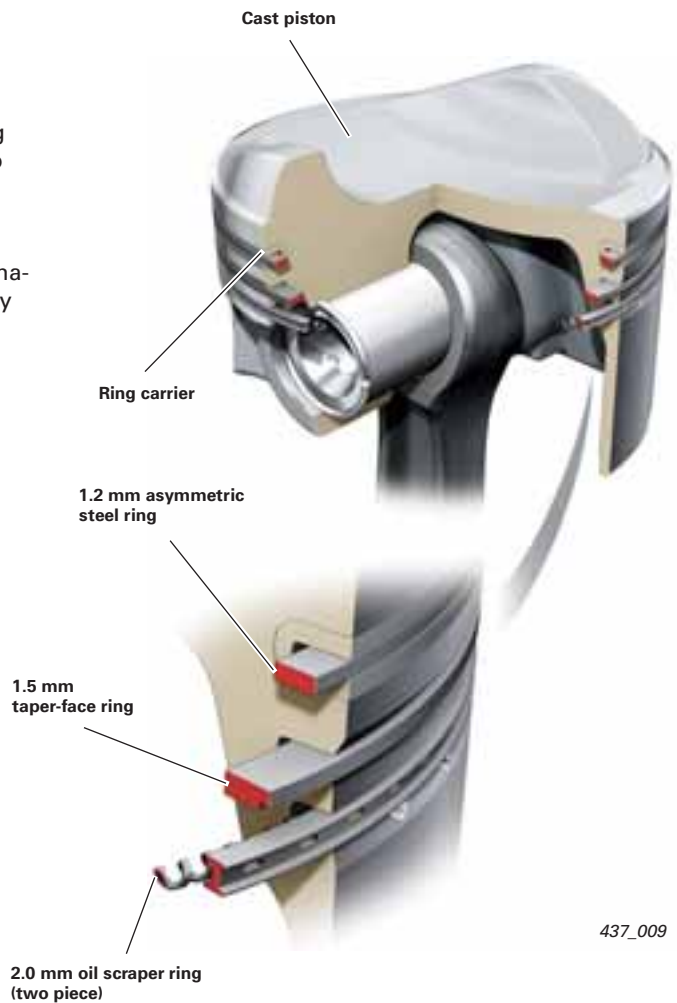

437_009

Crankcase ventilation

The crankcase is ventilated in the same way as on the 3.2l V6 FSI engine.

However, there is a difference with regard to the admission of treated crankcase ventilation gases. They are admitted along the shortest possible route directly from the V chamber preceding the rotors of the Roots blower.

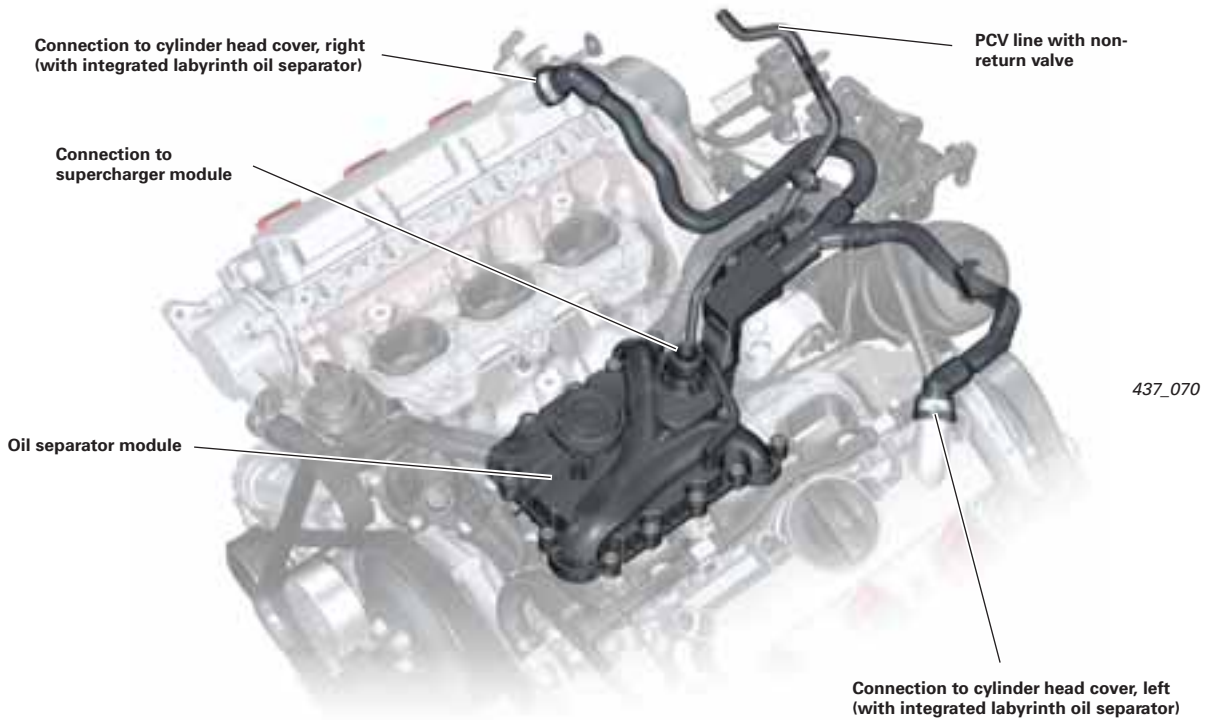

Connection to supercharger module

The *blow-by gases** are admitted into the supercharger module on the underside. An adaptor seals the feeder line off from the supercharger module. The opening in the supercharger module is tapered to aid inserting the adaptor.

The adaptor has a lug which can be used to position it exactly at the PCV outlet.



Reference

For a description of the design and function of the PCV system, please refer to Self-Study Programme 411 "Audi 2.8l and 3.2l FSI engine with Audi valvelift system".



Cylinder head

The four-valve cylinder heads will be adopted by and large unchanged from the 3.2l V6 FSI engine. The Audi valvelift system is not used in this engine-transmission unit.

It was also possible to dispense with the exhaust camshaft adjuster. However, an internal exhaust gas recirculation system has been implemented despite this.

Changes over 3.2l V6 FSI engine

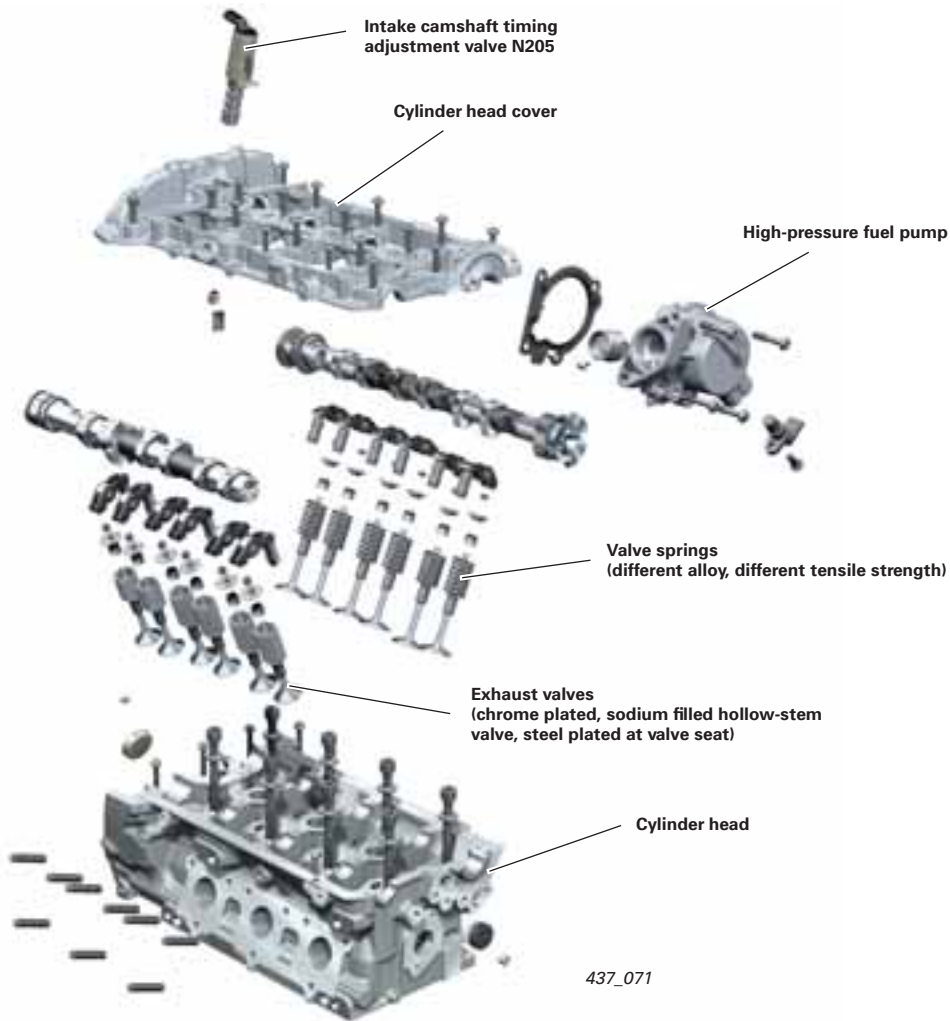

Chain drive

The chain drive is identical design to that of the 3.2l FSI engine. Differences are the modified *valve timing** and the absence of exhaust camshaft adjusters.



Engine mechanicals

Driving the ancillary units/components

The engine has two separate belt drives for driving the ancillary units/components. The ancillary units drive drives the alternator, the air conditioning compressor and the power steering hydraulic pump. The Roots blower is driven by a separate belt drive.

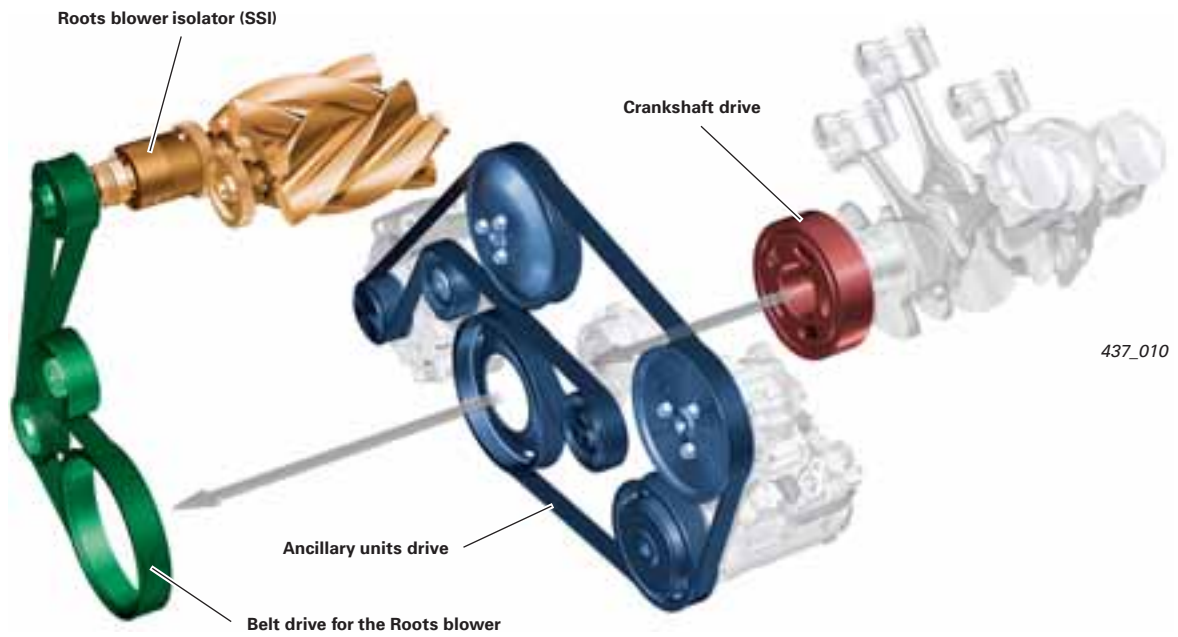

Layout of units

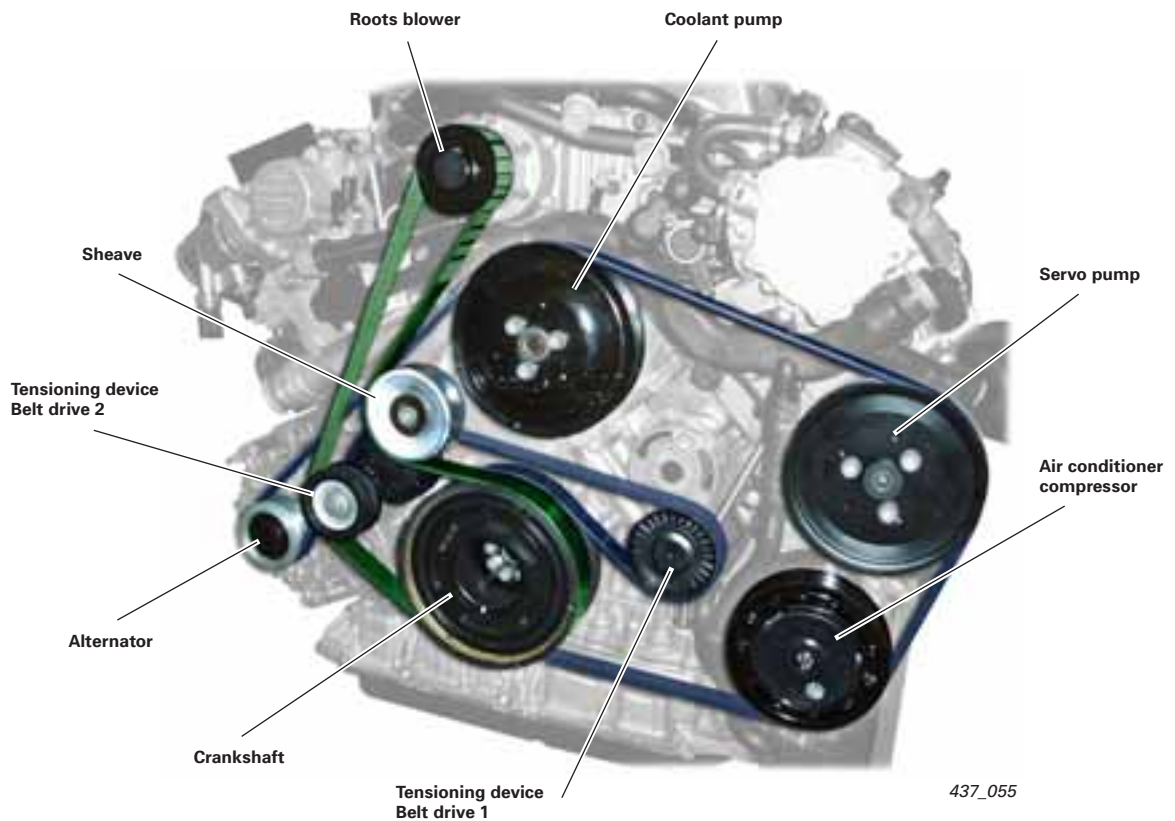

Oil circulation system

The oil circulation system of the 3.0l V6 TFSI engine was adopted from the 3.2l V6 FSI engine.

However, there are the following differences:

- There are no spray nozzles for the cam followers in the valve gear (they are only needed in an engine with Audi valvelift system, since the narrower rollers require better lubrication).
- There is no drive module for the exhaust camshaft adjuster

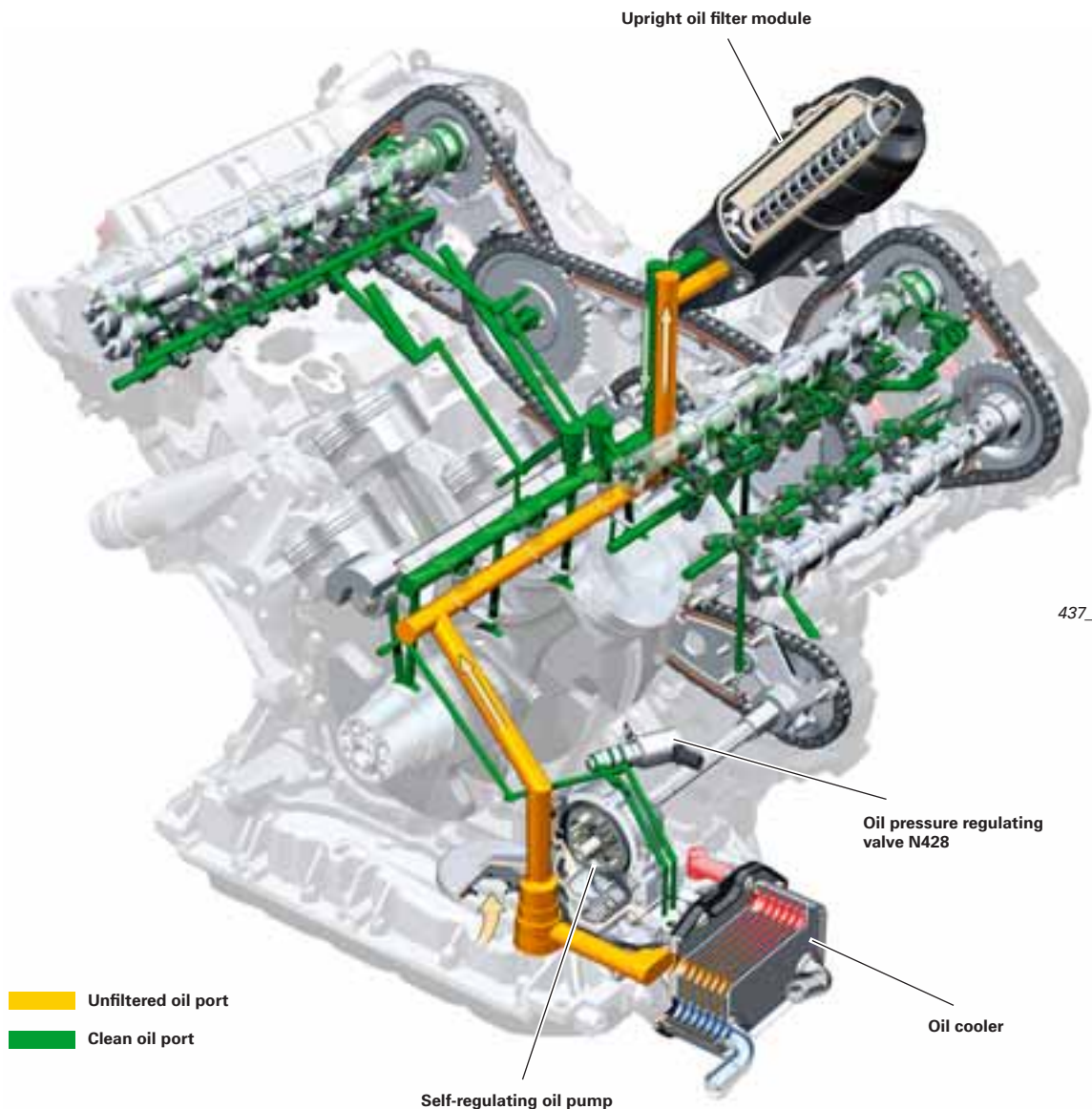

Reference

For a description of the design and function of the lubrication oil circuit and the oil pump, please refer to Self-Study Programme 411, "Audi 2.8l and 3.2l FSI engine with Audi valvelift system".



Air circulation system

The central component of the air supply is the supercharger module which sits inside the V shaped space between the cylinder banks. It comprises the Roots blower, the bypass control unit and the intercooler.

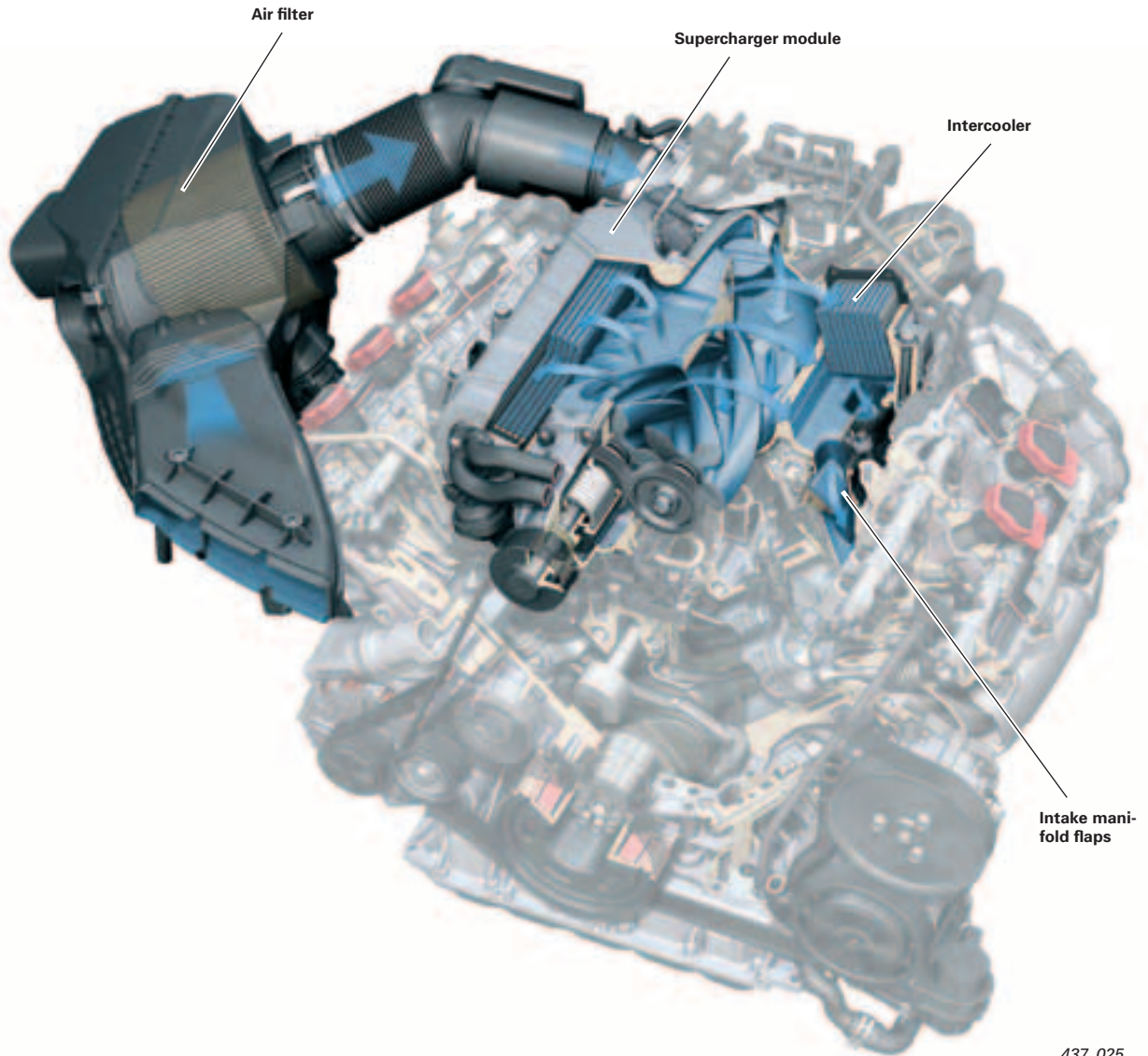

437_025

Given Audi's extensive experience with exhaust turbocharging, you may ask yourself why a mechanical supercharging system has been chosen for the 3.0l V6 TFSI engine.

After carefully weighing up the pros and cons on the basis of numerous tests conducted during the conceptual design and development phase, the decision fell in favour of the mechanical supercharging system.

The following criteria played a key role:

- High standard of comfort
- Good starting performance, coupled with a broad range of characteristics between comfort-oriented and ultra-sporty
- On account of this characteristic, the engine is suitable for use in multiple models (ranging from the Audi A4 to the A8).
- Compliance with all current and forthcoming exhaust emission standards (EU V and ULEV II)

Pros and cons of a mechanical supercharging system with Roots blower compared to an exhaust turbocharging system

Pros:

- Charge pressure is immediately available whenever it is required
- Charge pressure is continuously supplied and rises with increasing rpm.
- The charge air does not have to be cooled to such a great extent.
- Long life and maintenance-friendly operation
- Compact design (to save space, the supercharger can be installed in place of the intake manifold inside the V shaped space between the cylinder banks)
- High fuel efficiency
- Quick and dynamic torque response; peak torque is available at low rpm, providing good starting performance
- The compressed air paths to the cylinders are very short, resulting in a very low air volume and extremely quick response.
- Enhanced exhaust emission characteristics (reason: the catalytic converter reaches its operating temperature more quickly). In an exhaust turbocharged engine, a portion of the heat energy is wasted in driving the turbocharger.

Cons:

- It is very difficult to produce because very close manufacturing tolerances have to be maintained (rotor to housing and rotor to rotor)
- Higher susceptibility to ingress of foreign matter into the filtered air tract
- Relatively high weight
- Extensive soundproofing is needed
- Some engine power is lost in driving the blower.

Exhaust turbocharger



437_053

Roots blower



437_044

Air supply

General information on Roots blowers

With their mechanical supercharging technology, Roots blowers are presently staging a comeback at Audi. In this section you will find general information about the design and development of this technology.

Basic principle

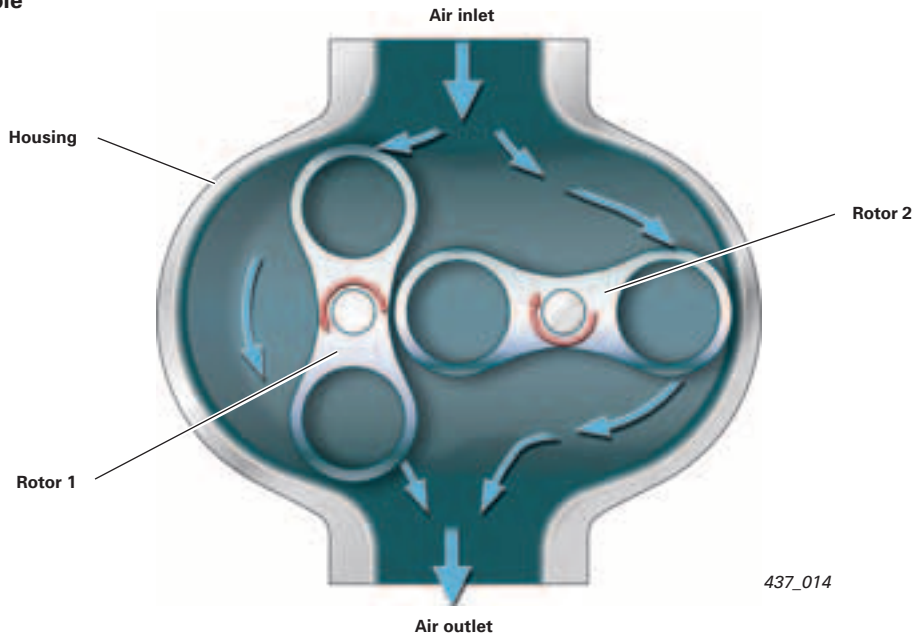

What are Roots blowers? In design terms, Roots blowers are rotary piston compressors. They work without inner compression according to the displacement principle. The fresh air blower consists of a housing in which two shafts (rotors) rotate. Both rotors are driven mechanically, e.g. by the crankshaft. Both rotors are coupled by a gearing outside the housing so that they counter-rotate synchronously. That is how they interact.

From a design standpoint, it is very important that the rotors are sealed off against each other and against the housing. The difficulty here is that no friction must be allowed to develop. When the blower is operating (i.e. the rotors are rotating), air is conveyed between the vanes and the outer wall of the housing from the air inlet (on the intake side) to the air outlet (on the pressure side). The pressure of the conveyed air is produced by reverse flow.

Types



The historic blowers of yesteryear were equipped with twin-vane rotors.



Today's modern versions usually have three vanes and are screw shaped to provide a higher and - above all - constant charge pressure (for better efficiency).

Historical evolution

The system is named after brothers Philander and Francis Roots, who had the principle patented as long ago as 1860.

At that time Roots blowers were principally used as wind generators for blast furnaces, but also found uses in other branches of industry. A Roots blower was used in an automobile for the first time by Gottlieb Daimler in 1900. In the 1920s and 1930s, Roots blowers were introduced into motorsport .

Special feature: these engines can be easily identified by their typical "compressor squeal" sound. The illustration below shows a Roots blower from the 1936 AUTO UNION Type C grand prix racing car. With the development of highly temperature-resistant materials, the Roots blower was superseded by the exhaust turbocharger. Today, Roots blowers are mainly used on sporty vehicles.

The difference between the AUTO UNION racing car and the 3.0l V6 TFSI engine is that, on the former, the air-fuel mixture was formed upstream of the Roots blower. This configuration was chosen for conceptual reasons, because the partial vacuum needed to draw fuel out of the carburettor was only available upstream of the Roots blower. In the Roots blower, therefore, the air-fuel mixture was compressed.

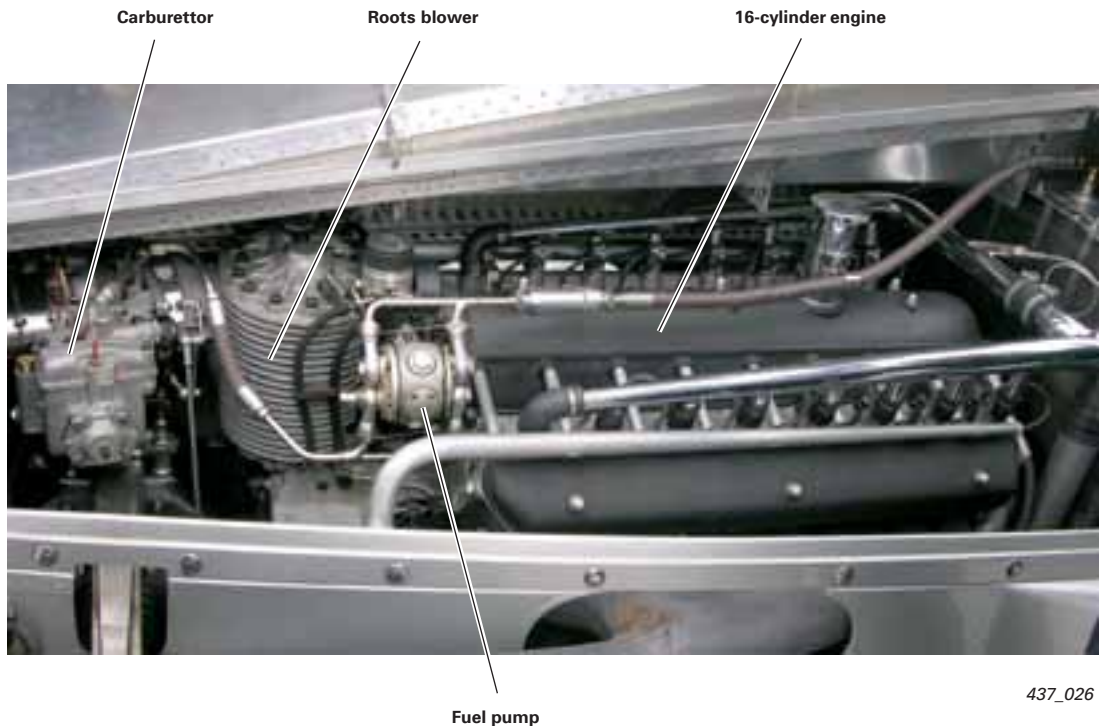
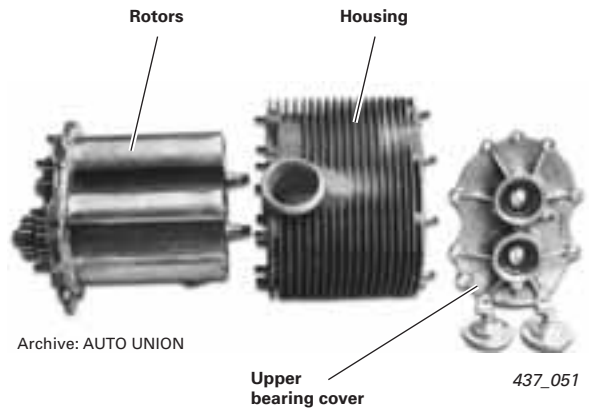

Supercharger module

Modern Roots blowers of the type used on Audi models are configured as twin-screw superchargers. Whereas the predecessor generation had three-vane rotors, the Audi Roots blower has four-vane rotors. Each vane of the two rotors is set at an angle of 160° relative to the longitudinal axis to provide a more continuous air flow with less pulsation.

The Roots blower for the 3.0l V6 TFSI engine is manufactured by EATON. This company already has many years of experience in the manufacture of Roots blowers.

Design

The entire supercharger module sits inside the V shaped space between the cylinder banks, so the engine is flat and meets pedestrian safety regulations. The total weight of the module is 18 kg (excluding coolant).

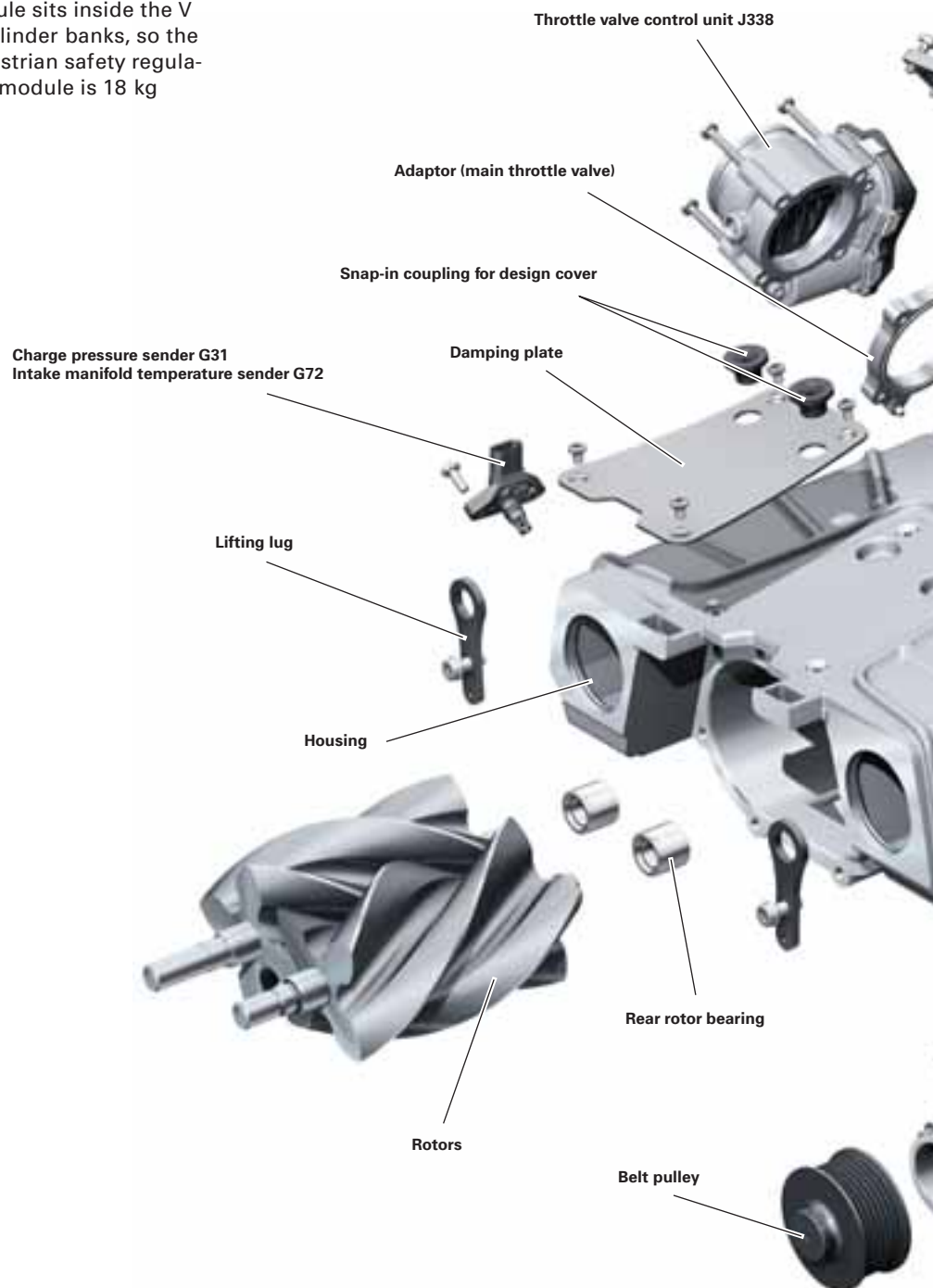

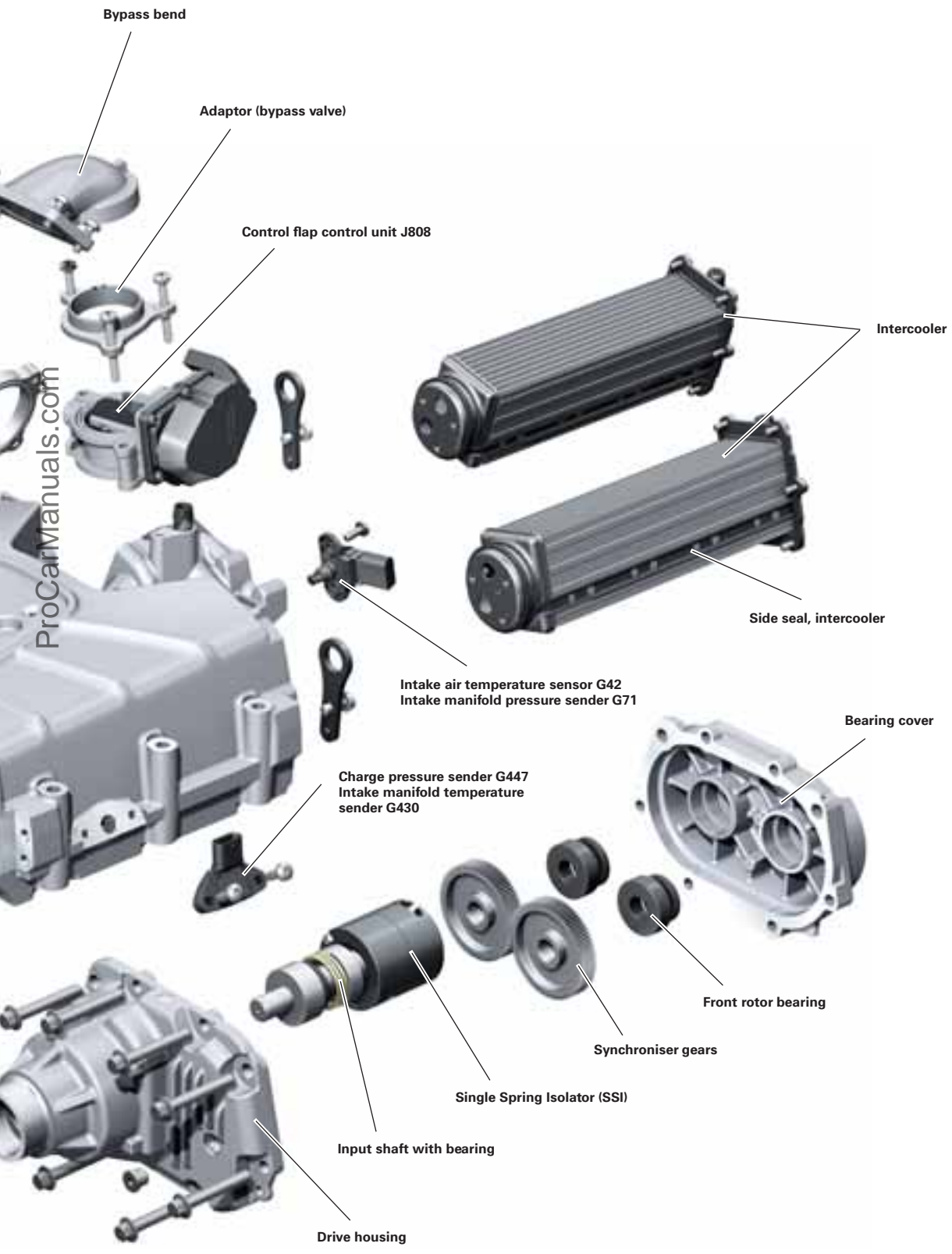

ProCarManuals.com

437_037

Air supply

Housing

The Roots blower, an electrically activated bypass valve and one intercooler per cylinder bank are integrated in a cast mono-block housing.

The air outlets to the individual cylinders can be found on the underside of the housing. The lifting lugs bolted to the supercharger module are for suspending the engine during removal and installation.



Drive

The Roots blower is driven by the crankshaft via the second pulley of the belt drive. Drive is permanent, and is not engaged or disengaged by a magnetic coupling. Each belt drive is insulated against crankshaft vibration by a rubber buffer in a shared torsion vibration damper.

The result is better resonance damping at low engine speeds and full throttle. Spin-off: the load on the belt is significantly lower.

The crankshaft-to-supercharger drive ratio is 1:2.5. This means that a maximum engine speed of 18,000 rpm is possible.

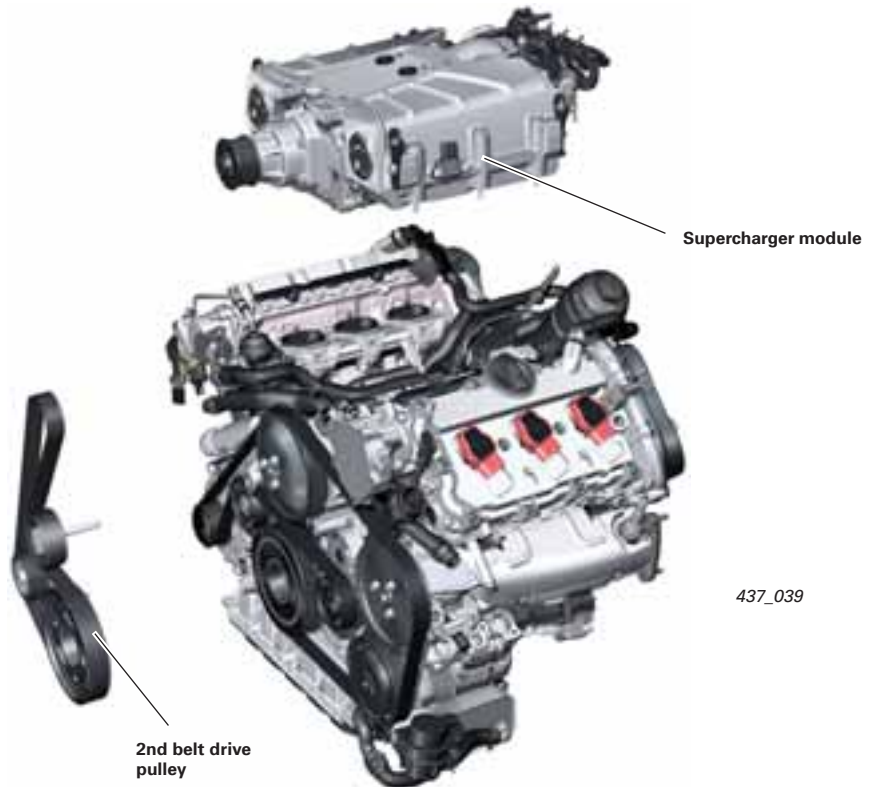

The Roots blower is coupled by means of a Single Spring Isolator (SSI) integrated in the drive housing of the supercharger module. The SSI is designed to optimise force transmission under load reversal.

It ensures very smooth running (optimised acoustics) and extends the life of the drive belt. The ribbed V-belt which drives the Roots blower has a replacement interval of 120,000 km.

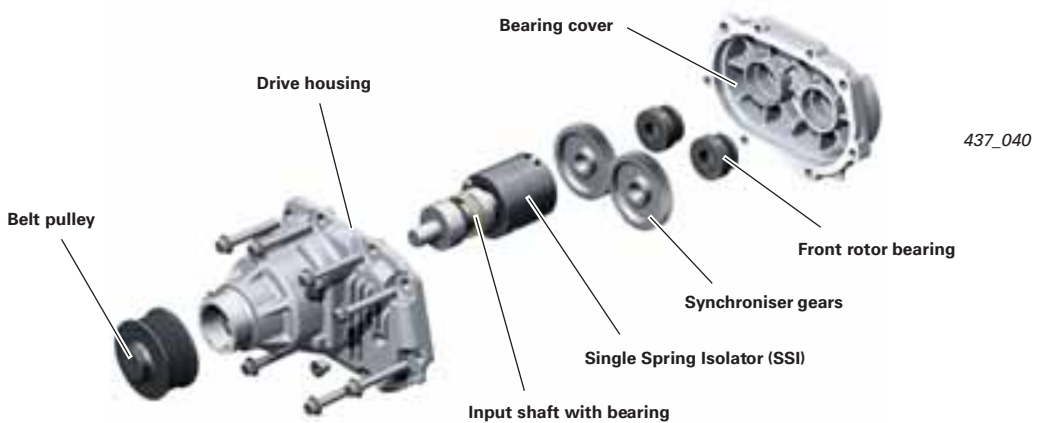

Air supply

Function

A spring element is built into the drive housing of the Roots blower. It consists of a torsion spring guided by an input bushing and an output bushing and transmits drive torque from the belt pulley to the gearing.

The input and output bushings limit the excursion of the spring, both in and counter to the direction of rotation of the Roots blower.

The spring element is rated "soft" enough to effectively isolate the blower, yet also firm enough to prevent harshness during dynamic operation (under load reversal), which can cause unwanted noise.

Further along the drive-line, the second rotor is driven through a pair of gears, with the result that the two rotors counter-rotate absolutely synchronously. The large number of teeth serves to reduce vibration transmission. The gears are press fitted onto the rotor shafts by the manufacturer using special gauges.

A perfect fit must be ensured, as the rotor vanes would otherwise come into contact with one another.

For this reason, the gears must not be removed from the shafts during servicing. The drive head is filled with special-grade oil.

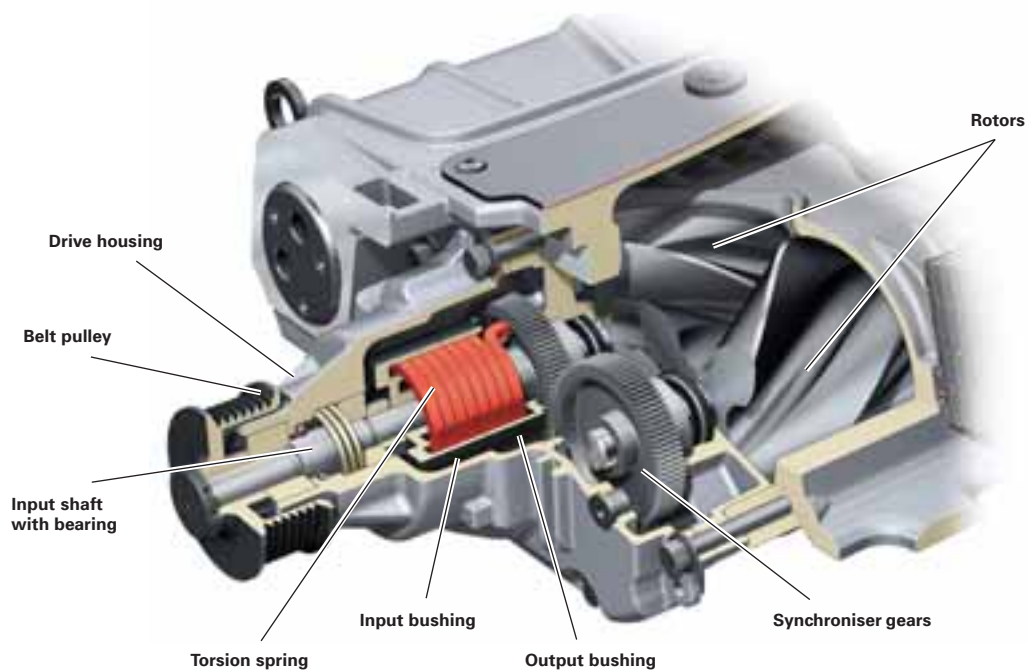

437_041

Rotors

The two four-vane rotors are set at an angle of 160° and run on maintenance-free roller bearings. To minimise wear during the run-in phase, the rotors have a special graphite-based coating. This coating also guards against air leakage (rotor to rotor, rotor to rotor bore), which means better performance.

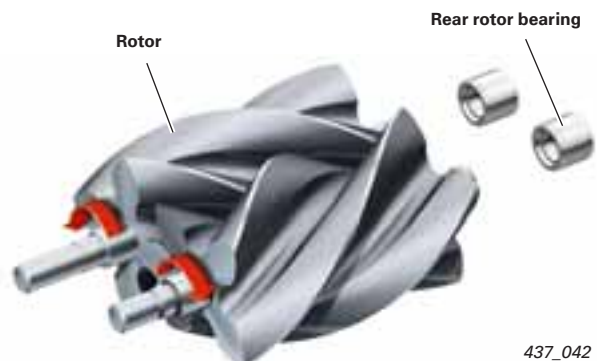

437_042

Control of air flow and charge pressure

The Roots blower is permanently driven. Without a charge pressure control system, the Roots blower would always deliver the maximum air flow rate for each engine speed and therefore generate the maximum charge pressure.

However, charged air is not required in all operating states, so there would be an excessive build-up of air on the pressure side of the blower. This would, in turn, lead to an unnecessary loss of engine power. Therefore, it is necessary to regulate charge pressure.

In other systems, a magnetic coupling shuts off the belt drive to limit the charge pressure.

In the 3.0l V6 TFSI engine, the control flap control unit J808 is used to regulate the charge pressure. It is integrated in the supercharger module and connects the pressure side to the intake side. By opening a bypass valve, a portion of the air flow is recirculated through the open bypass to the intake side of the Roots blower.

The bypass valve works in much the same way as a wastegate on an exhaust turbocharged petrol engine.

Tasks of the control flap control unit J808:

- Regulation of the charge pressure defined by the engine control unit
- Limitation of maximum charge pressure to 1.9 bar (absolute)

Function

Full-throttle operation (bypass valve closed)

When the engine is running at wide open throttle, air flows through the throttle valve, Roots blower and intercooler to the engine.

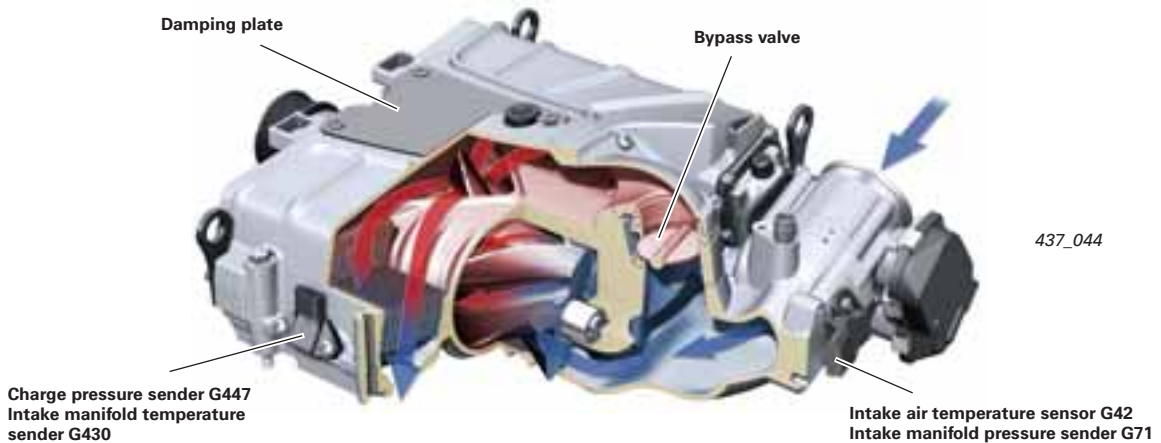

Part-throttle mode (bypass valve open)

When the engine is running at part throttle, at idling speed and when coasting, a portion of the airflow is recirculated through the open bypass valve to the intake side.

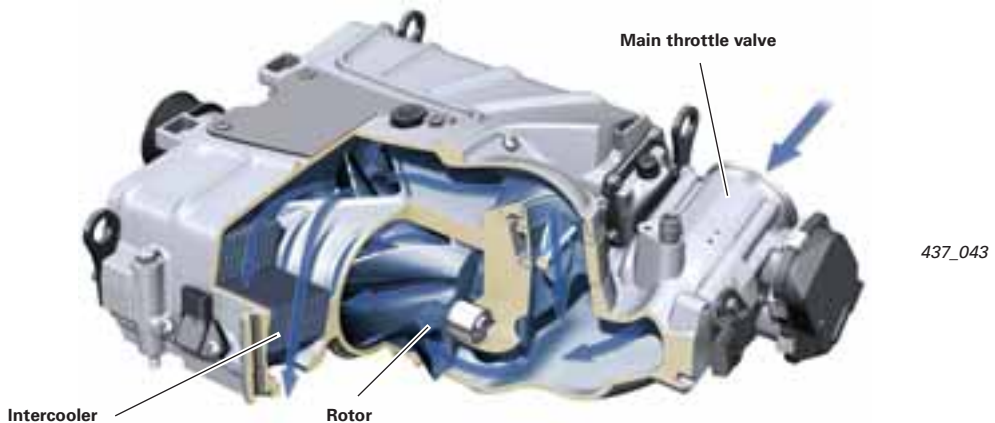

Air supply

Control flap control unit J808

Use of the control flap control unit J808 eliminates the need for complex and expensive belt drive shut-off in the form of a magnetic coupling. The power consumption of the supercharger module is between 1.5 and 38 kW, depending on engine speed.

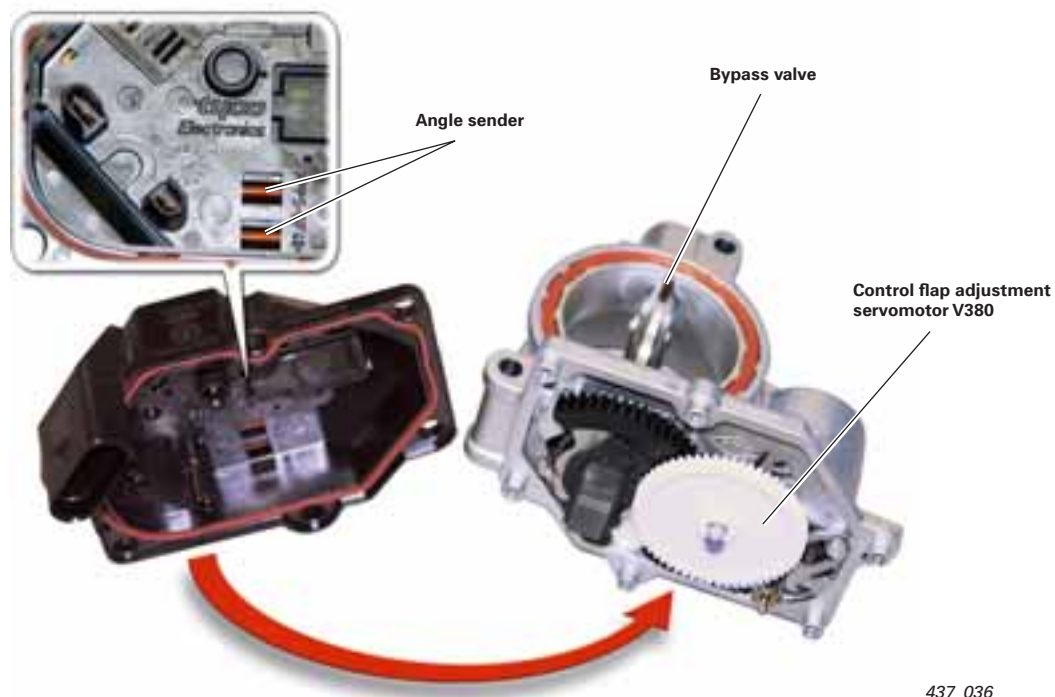

437_036

Signal characteristic of the control flap potentiometer G584

- ① Lower mechanical stop
- ② Upper mechanical stop

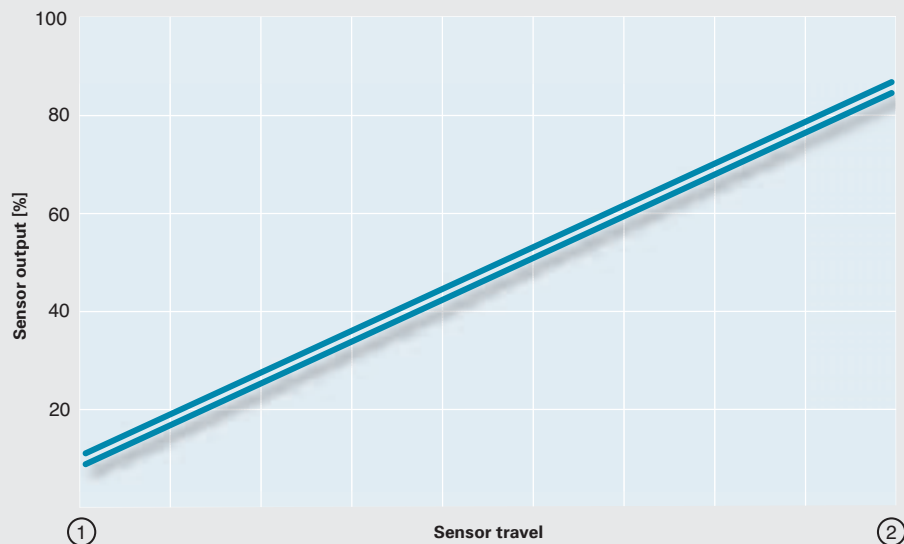

Legend:

- G584 Control flap potentiometer
- J808 Control flap control unit
- V380 Control flap adjustment servomotor (type: DC motor)

- ① Sensor voltage earth
- ② Control signal
- ③ Positive sensor voltage
- ④ } Motor supply voltage
- ⑤ }

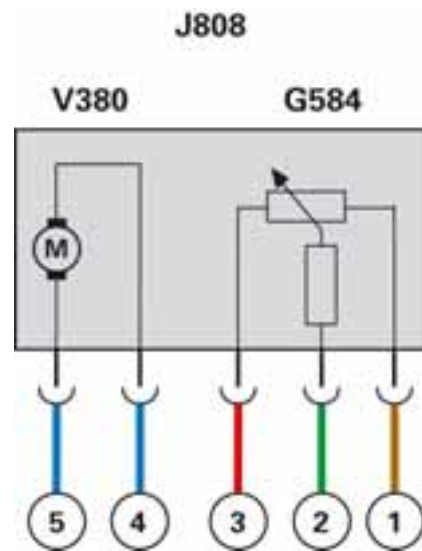

437_052

Control flap potentiometer G584

This component senses the current position of the control flap and is integrated in the actuator housing cover. Its output voltage range is between 0.5 and 4.5 V. The potentiometer operates on the magneto-resistive measurement principle and, therefore, is immune to electromagnetic radiation (EMC*).

Effects of signal failure

The flap is de-energised and moves into its wide open position under spring load. The fault is irreversible for the duration of one driving cycle. In this case, no charge pressure is built up. Neither the full engine power output nor the full engine torque is available. This component is subject to OBD; i.e. if it fails, the exhaust gas warning lamp K83 (MIL) is activated.

Signal utilisation

The flap position feedback signal is utilised to determine the control input variable. It is also used to determine the adaptation values.

Reference

For more information on magneto-resistive sensors, please refer to Self-Study Programme 411, "Audi 2.8l and 3.2l FSI engine with Audi valvelift system".



Air supply

Sensors for the measurement of air mass and charge pressure

Air mass and charge pressure are used as main control variables for engine load management. For this purpose, there are three sensors with absolutely identical functions. They measure the intake air temperature and the intake manifold pressure. The first sender unit is located upstream of the throttle valve control unit J338 and comprises the following senders:

- Intake air temperature sensor G42
- Intake manifold pressure sender G71



437_028

The other, identical senders are integrated in the supercharger module. They measure the pressure and temperature of the air in each individual cylinder bank. It is important that the measuring point be located downstream of the intercoolers. The values measured here correspond to the actual air mass in the cylinder banks. The senders are as follows:

- Charge pressure sender G31 (cylinder bank 1)
- Intake manifold temperature sender G72 (cylinder bank 1)
- Charge pressure sender G447 (cylinder bank 2)
- Intake manifold temperature sender G430 (cylinder bank 2)

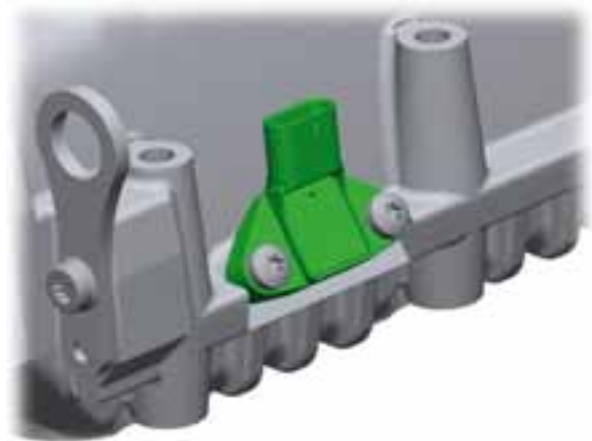

437_029

Circuit diagram

The intake air temperature sensor G42 is a temperature sensor with a negative temperature coefficient (NTC). It outputs a voltage signal to the engine control unit.

Legend:

- G42 Intake air temperature sensor
- G71 Intake manifold pressure sender
- 15 Terminal 15
- 31 Terminal 31

- ① Voltage signal for intake manifold pressure
- ② Resistance signal for intake air temperature

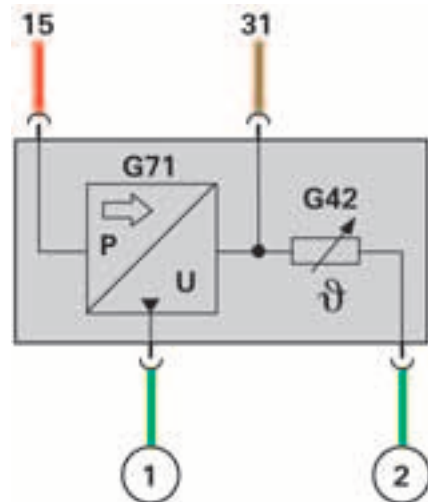

437_018

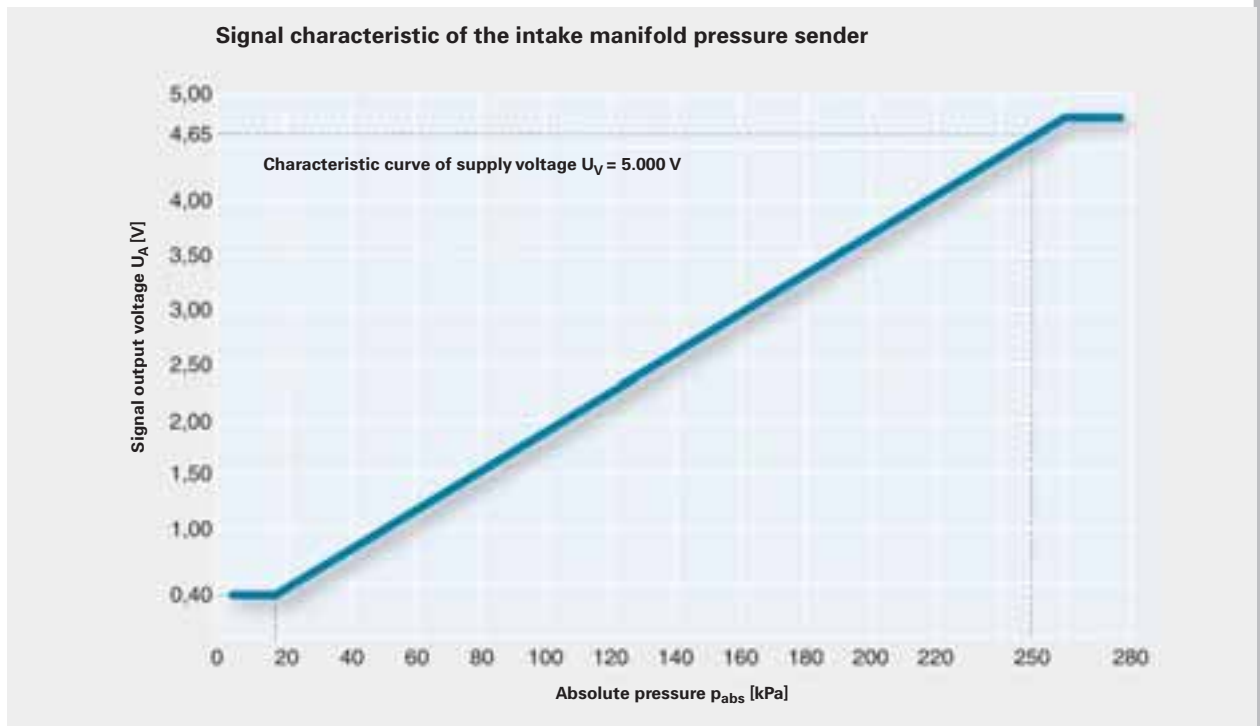

Signal utilisation

The signal generated by the intake manifold pressure sender G71 upstream of the throttle valve control unit is used to pre-determine the nominal position of the bypass valve.

This information is required to set the requisite charge pressure. This nominal position of the bypass valve depends largely on the pressure level upstream of the supercharger module.

Charge pressure senders G31 and G447 serve firstly to adjust the charge pressure to the required nominal value. Secondly, the air mass is calculated from their output signal during each working cycle. This air mass is a key input variable of the torque-based engine management system, which determines the injection rate, injection timing and ignition advance angle.

Effects of signal failure

In case of signal failure, the exhaust gas warning lamp K83 (MIL) is activated. Failure of the intake manifold pressure sender G71 will result in less precise adjustment of the charge pressure, which in turn can become apparent to the driver in the form of uneven acceleration.

Failure of charge pressure senders G31 and G447 will result in an incorrect composition of the air-fuel mixture throughout the load/speed range because an erroneous air mass will be computed.

This will in turn cause an incorrect quantity of fuel to be injected, resulting in higher exhaust emissions and loss of power (and even misfiring).



In charging mode, a fault in this sender can result in wrong charge pressures, causing irreparable damage to the engine.

For this reason, all senders are validated after the ignition is turned on. If irregularities are detected, an entry will be made in the fault memory and the system switches over to an equivalent sensor or the backup sender. In this way, the system will operate as normal from the driver's viewpoint and consequential damage will be avoided.

Circuit diagram

Legend:

- G31 Charge pressure sender (cylinder bank 1)
- G72 Intake manifold temperature sender (cylinder bank 1)
- G430 Intake manifold temperature sender (cylinder bank 2)
- G447 Charge pressure sender (cylinder bank 2)
- J623 Engine control unit
- V_s Supply voltage (5 volts)

-  Positive
-  Ground
-  Sensor signal

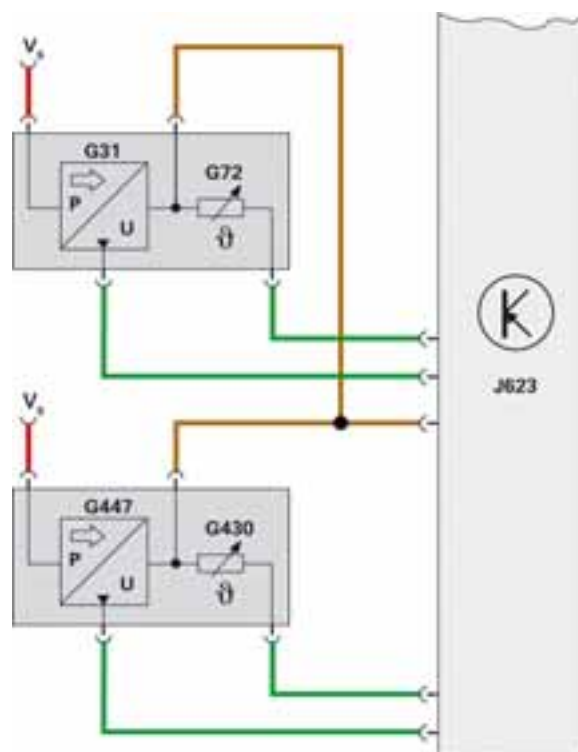

437_020

Load management

The control flap control unit J808 operates in conjunction with the throttle valve control unit J338.

The focus during the development of the control system was on maximising throttle-free operation and power delivery.

The following diagram shows the functions of both flaps. During part-throttle and naturally aspirated operation, the bypass valve is wide open and the engine throttle valve takes care of load management. In charge pressure mode, the bypass valve regulates the engine load and the engine throttle valve is wide open.

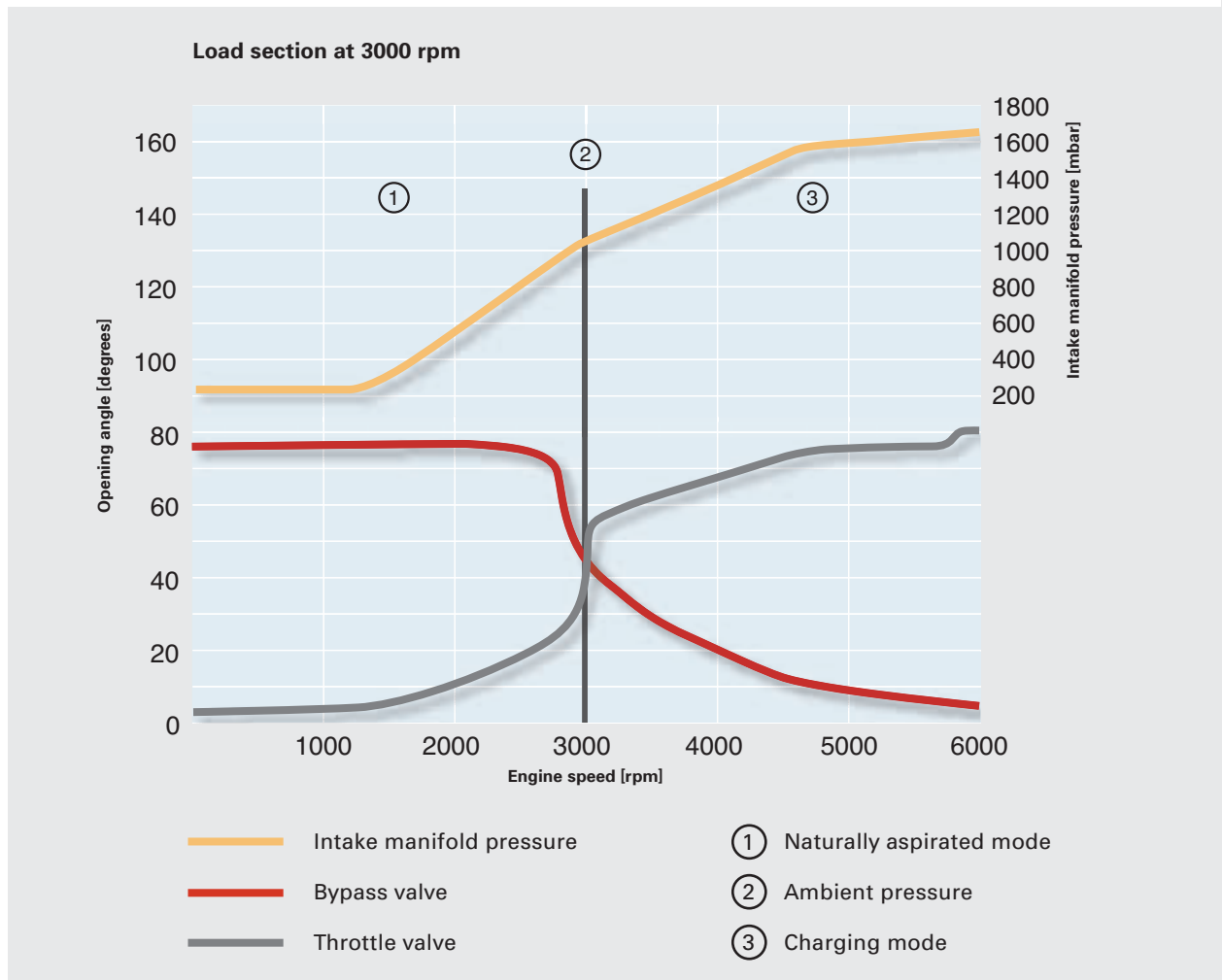

Intake manifold flaps

Intake manifold flaps are used on the 3.0l V6 TFSI engine to improve internal mixture formation. They are housed in an adaptor element between the supercharger module and the cylinder head.

Note



To fit the adaptor element, the intake manifold flaps must be moved into the "power" position (intake port open).

Intake manifold flap module, left cylinder bank

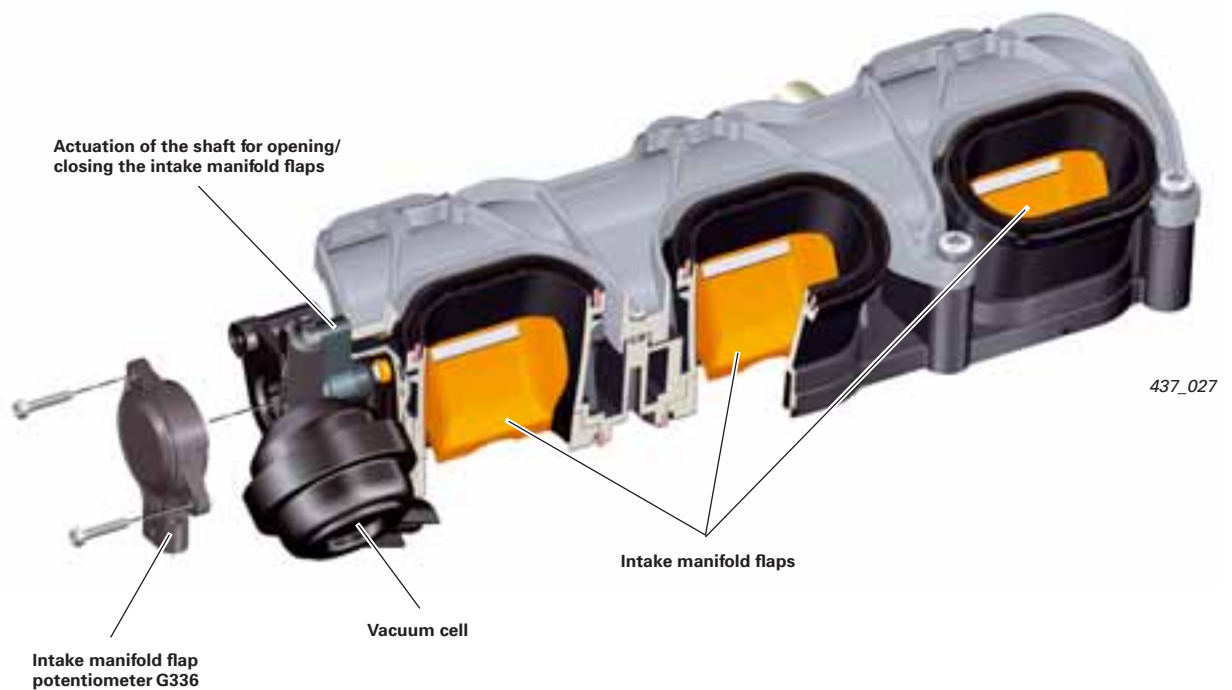

Intake manifold flap valve N316

The intake manifold flaps are mounted on a common shaft and actuated by a vacuum cell. The partial vacuum required for this purpose is supplied by the intake manifold flap valve N316. The engine control unit activates the intake manifold flap valve N316 on the basis of a characteristic map.

Effects of failure

If N316 is not activated or faulty, no partial vacuum will be supplied. In this condition, the intake manifold flaps close the "power" port in the cylinder head under the spring pressure produced by the vacuum cell, thereby reducing engine output.



437_049

Intake manifold flap potentiometer

Two senders monitor the positions of the intake manifold flaps:

- Cylinder bank 1: Intake manifold flap potentiometer G336
- Cylinder bank 2: Intake manifold flap potentiometer 2 G512

The senders are integrated directly in the vacuum cell flange. They are contactless incremental encoders and work on the *Hall sender** principle. The sensor electronics generate a voltage signal, which is evaluated by the engine control unit.

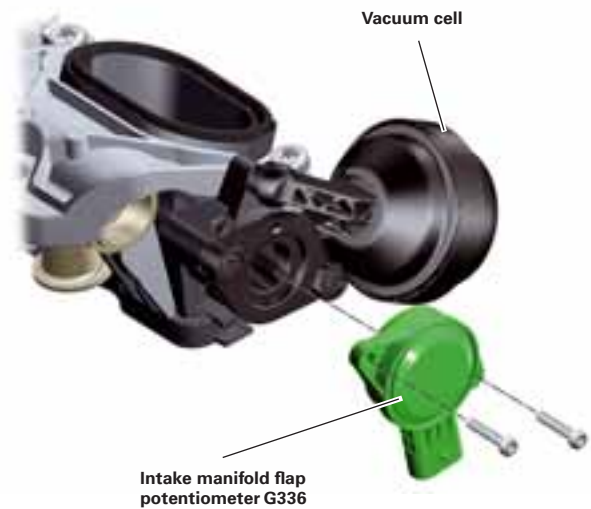

437_030

Signal utilisation

The signal is used to monitor the position of the intake manifold flap and for diagnostic purposes (e.g. to check for wear etc.).

Effects of signal failure

The position of the intake manifold flap will no longer be correctly sensed. No diagnosis will be possible. This component is subject to OBD; i.e. if it fails, the exhaust gas warning lamp K83 (MIL) is activated. Loss of power can occur.

Signal characteristic of the intake manifold flap potentiometer

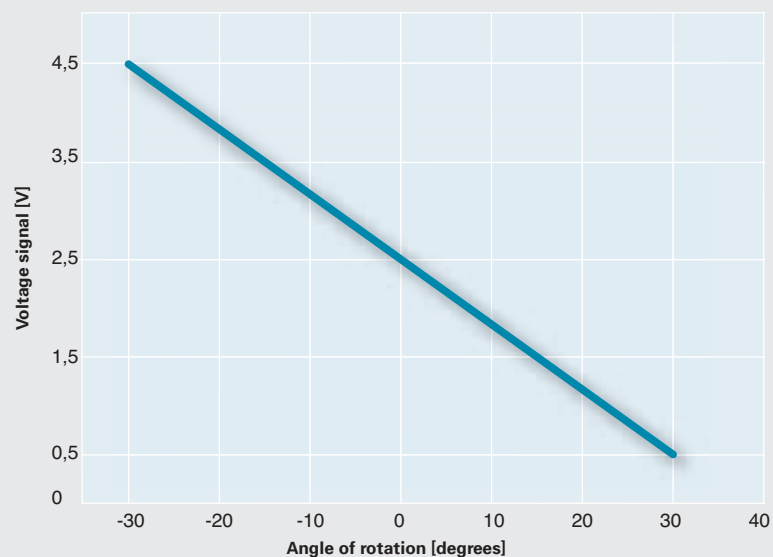

Soundproofing

A further development goal was to keep the sound emission of the Roots blower to a minimum. This was achieved by modifying the design of the housing. A multilayer damping plate reduces noise at the gas outlet on the Roots blower.

Noise is also reduced by modifications to the intake (see figure). Insulating mats positioned around and below the supercharger module provide additional soundproofing.

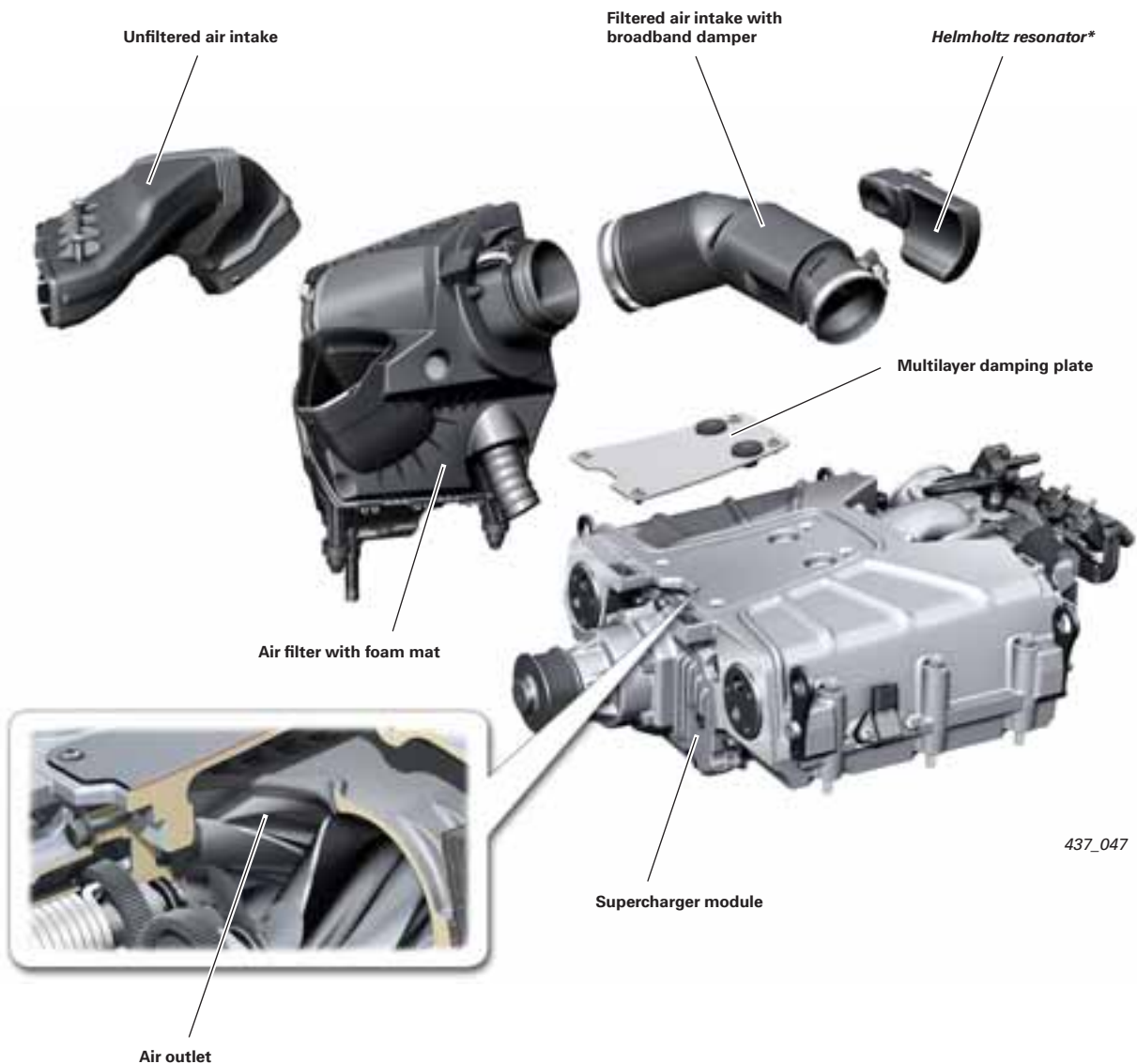

437_047

Insulating mats

Multiple insulating mats are positioned between the supercharger module and the cylinder head and block.

They reduce the noise emission of the Roots blower in a downward direction. Two small insulating inserts are located on the back of the supercharger module (see adjacent figure).



437_031

Additional insulating mats are located below the supercharger module inside the V shaped space between the cylinder banks.

A larger mat is positioned between the two intake manifolds, and there are two narrower insulating mats at the sides between the intake manifolds and the cylinder heads.



437_032

The adjacent figure shows the insulating mats installed between the supercharger module and the cylinder head or block.



437_033

Cooling system

Cooling circuit

There are two different types of cooling circuit for the Audi A6 with 3.0l V6 TFSI engine (they are market dependent).

The adjacent figure shows a version with preheater and coolant run-on pump V51 (for super-hot climates PR No.: 8z9).

Another electrically driven coolant pump is the intercooling pump V188, which is used in the low-temperature circuit of the intercooler.

However, both circuits are interconnected and share a common coolant expansion tank.

Note



Please refer to the instructions for filling and venting the coolant system in the relevant service literature.

Cooling circuit without preheater

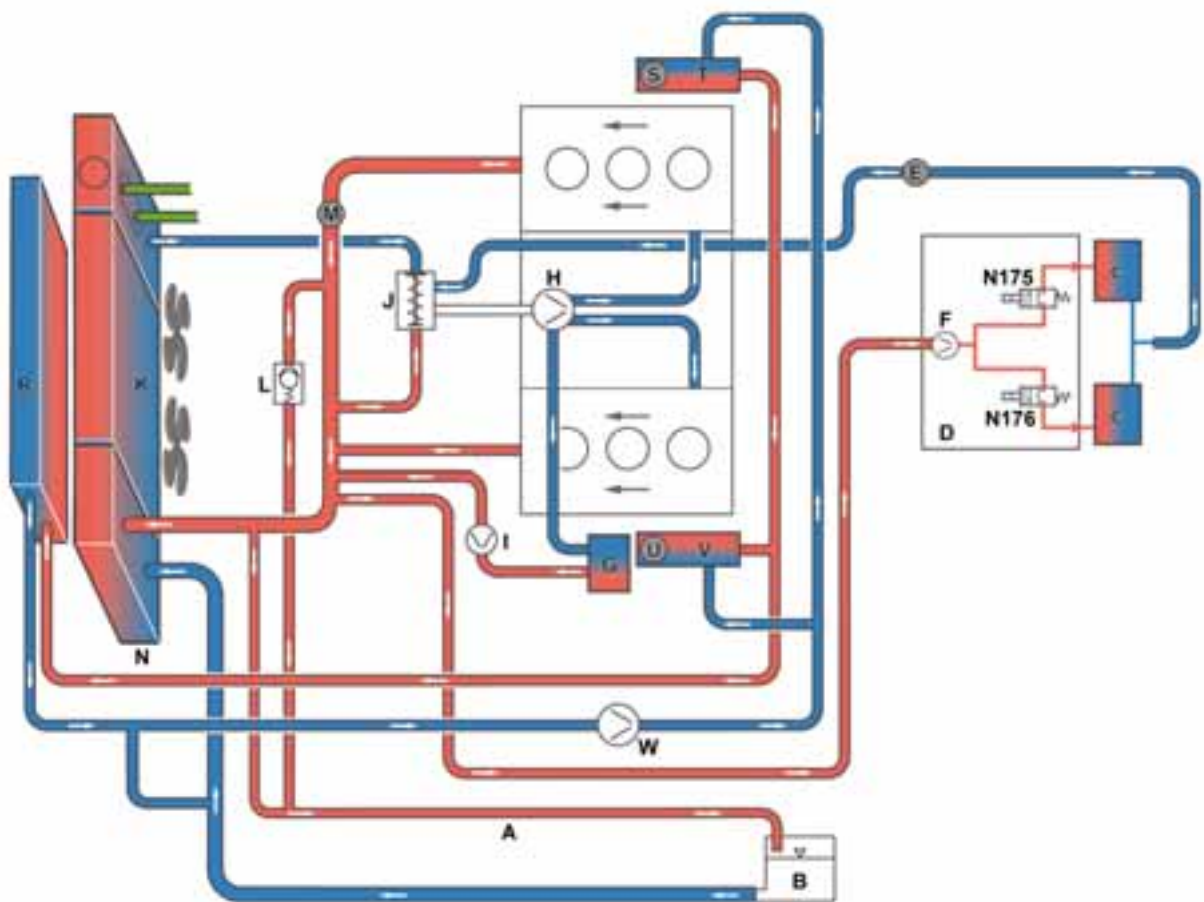

437_013

Cooling circuit with preheater

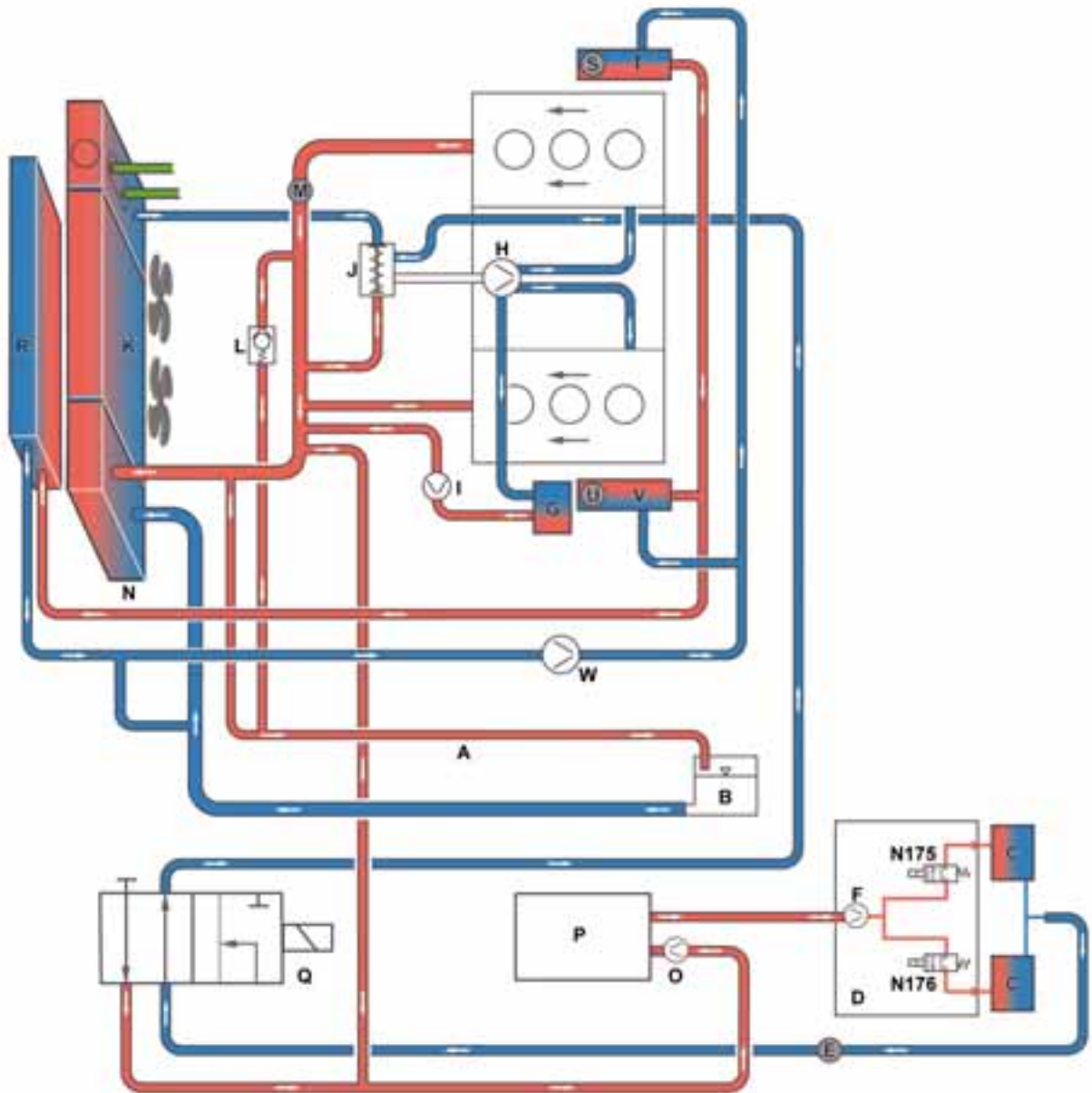

ProCarManuals.com

437_012

Legend:

- | | | | |
|---|---|------|------------------------------------|
| A | Vent line | N | ATF cooler |
| B | Expansion tank | N175 | Heat regulation valve, left |
| C | Heat exchanger | N176 | Heat regulation valve, right |
| D | Pump/valve unit (N175/N176 and V50) | O | Recirculation pump |
| E | Vent screw | P | Pre-heater |
| F | Coolant circulation pump V50 | Q | Heater coolant shut-off valve N279 |
| G | Engine oil cooler | R | Auxiliary cooler, front |
| H | Coolant pump | S | Vent screw |
| I | Coolant run-on pump (hot climates only) | T | Intercooler, right |
| J | Coolant thermostat | U | Vent screw |
| K | Radiator | V | Intercooler, left |
| L | Non-return valve | W | Intercooling pump V188 |
| M | Coolant temperature sender G62 | | |

Cooling system

Charge air cooling (intercooling)

The supercharger module comprises one intercooler per cylinder bank. Coolant flows through the intercoolers, which are integrated in the intercooling circuit in a parallel configuration.

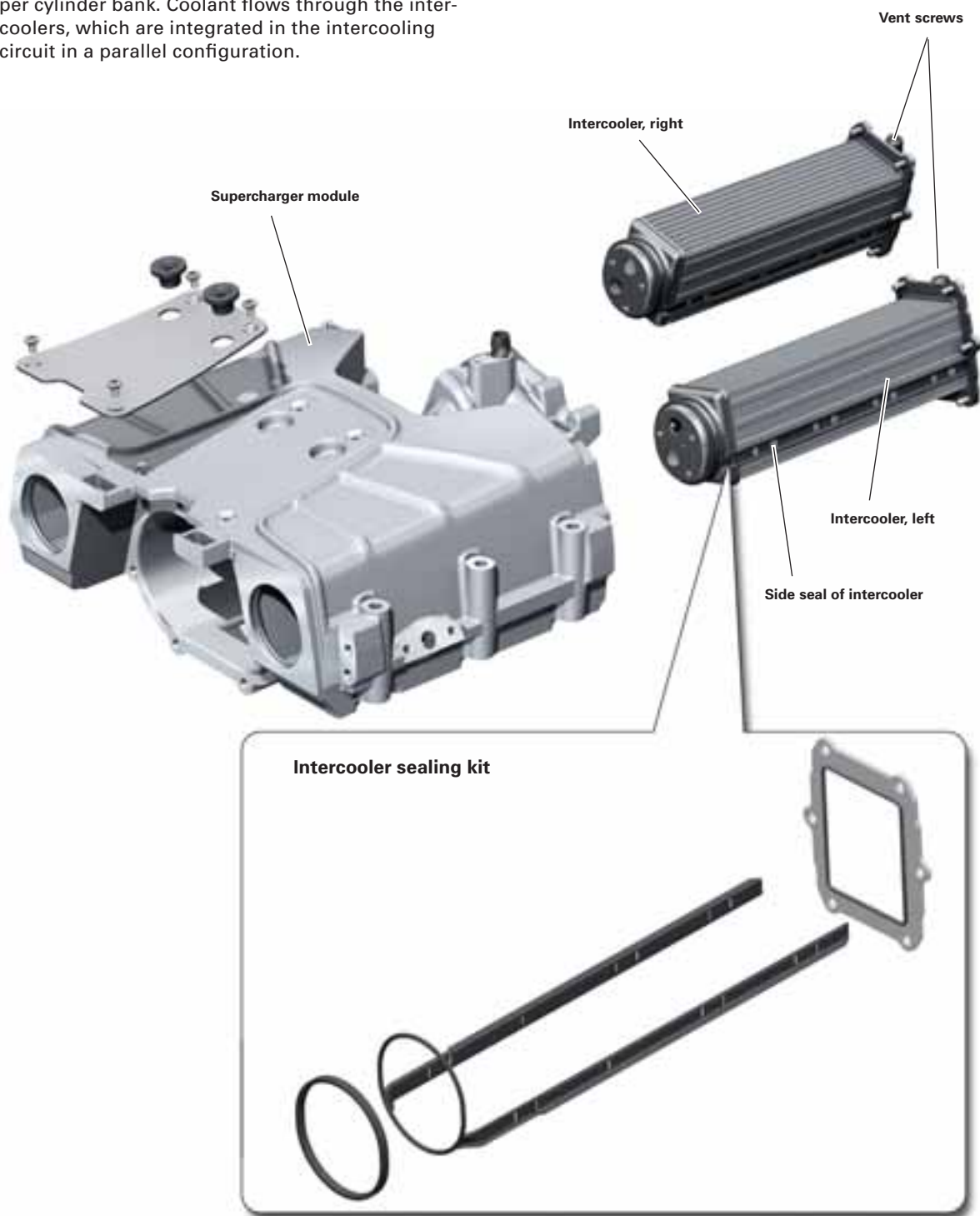

437_045

Note

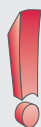

The intercooler must be installed and removed with the utmost care. Follow the instructions given in Workshop Manual.

Intercooling circuit

The intercooling circuit is a cooling circuit which is separate from the main cooling circuit. However, both circuits are interconnected and share a common coolant expansion tank.

The temperature level within the intercooling circuit is usually lower than within the primary circuit.

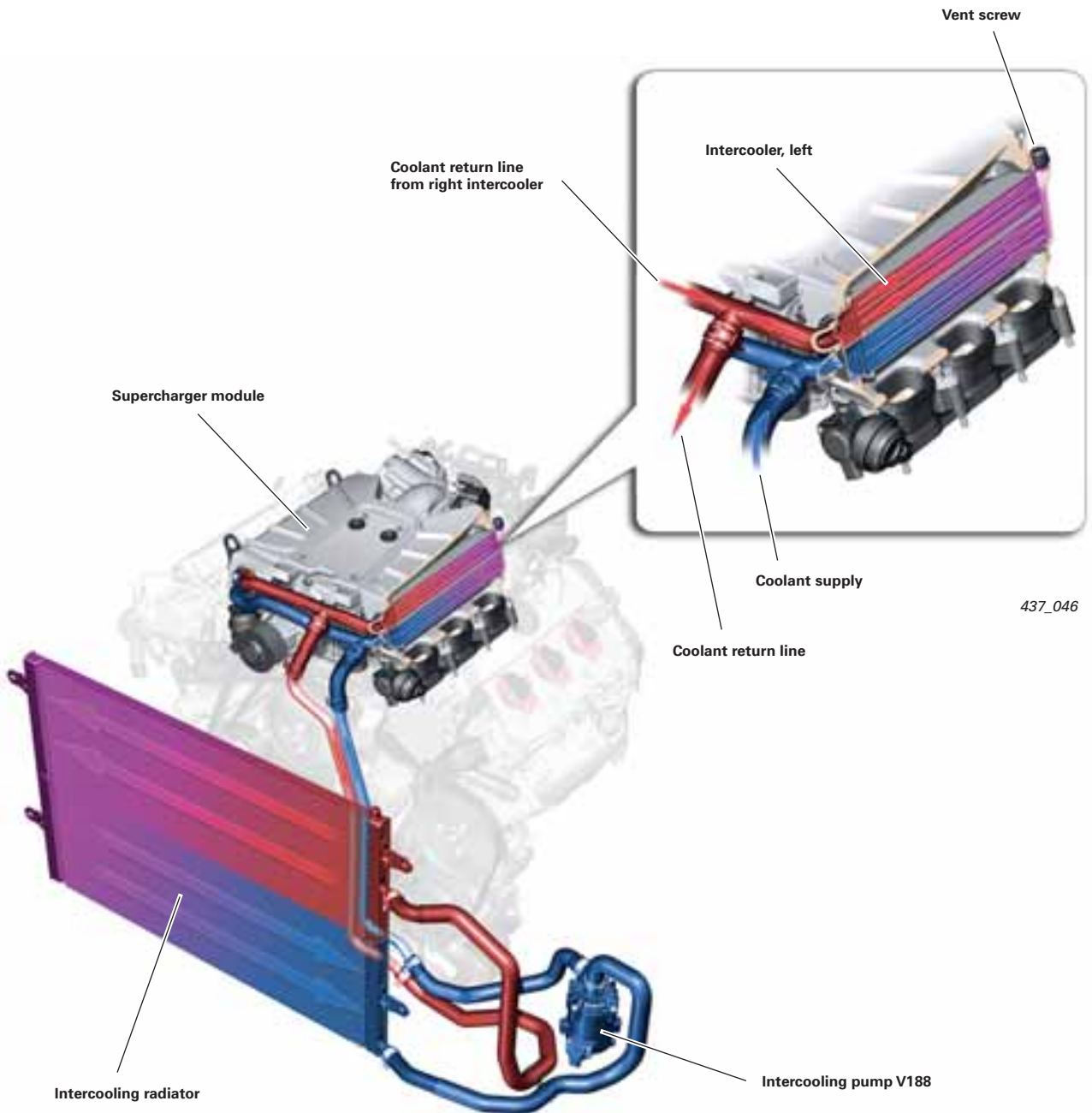

Cooling system

Intercooling pump V188

The intercooling pump V188 is an electrically driven coolant pump. This is the first time it is being used in a cooling system on an Audi car.

It pumps the heated coolant from the intercooler inside the supercharger module to the low-temperature cooler. The lower-temperature cooler is integrated in the cooling unit at the front end of the vehicle (in the direction of travel upstream of the radiator).

The pump is close coupled to the oil cooler at the front left of the engine bay.

The pump is configured as a centrifugal pump. A centrifugal pump is not selfpriming, and, therefore, must not be allowed to run dry. The pump bearings could otherwise overheat.

The following subassemblies are integrated in the pump module:

- Centrifugal pump
- Electric motor
- Electronic control unit

The electrical connection of the pump has three pins:

- Battery voltage from the automatic gearbox control unit J271
- *PWM signal**
- Terminal 31

How the pump control unit works

The pump is activated in dependence on the temperature and pressure downstream of the intercooler, both of which are read from a map stored in the engine control unit. In any case, the pump begins to run at a pressure of 1300 mbar or a coolant temperature of 50 °C.

The pump is activated by a PWM signal generated by the engine control unit. The pump electronics calculate from this signal the required pump speed and activate the electric motor.

If the pump is in order, the pump electronics feed the current pump speed back to the engine control unit. This process repeats itself cyclically throughout the duration of pump operation.



437_057

Effects of failure

If the pump electronics detect a fault, the PWM signal will be altered. The modified signal is evaluated by the engine control unit, which initiates a response corresponding to the nature of the fault.

If a fault is found, the fault is stored in the fault memory of the engine control unit. The loss of power due to failure of the pump will only be noticeable when the throttle is wide open. Exhaust emissions are not affected, and no warning lamp is activated.

If the pump fails, no substitute response is initiated in the engine control unit. However, the charge air temperature is monitored. If an excessively high charge air temperature is diagnosed, engine output will be reduced.

If the signal line to the pump is broken or if a short circuit to positive occurs in the signal line, the pump will enter an emergency mode in which it delivers 100 % output. If a short circuit to ground occurs on the signal line, the pump will stop.

Fault identification

If faults are found, the system will attempt to protect the pump either by reducing its speed or shutting it off.

The following table shows possible faults and their effects.

Faults detected by the pump	Effects
Dry-running due to low coolant level (speed higher than expected)	Speed reduction to 80 % (max. 15 min)
Low coolant level >15 min	Pump is shut down
Overtemperature	Speed is reduced in two steps, first to 80 % and then to 50 %
Undertemperature (excessively cold coolant and high viscosity* increase current draw)	Speed is reduced in two steps, first to 80 % and then to 50 %
Overvoltage	If the voltage is > 20 V, the pump will be shut down as long as overvoltage is present.
Rotor lockup	The pump is shut down. It attempts to work itself free.
Temperature of the pump electronics > 160 °C	The pump is shut down as long as the overtemperature is present.

Possibilities for diagnosis during servicing

The following possibilities for diagnosis are available:

- Read out fault memory in engine control unit
- Guided Fault Finding function (test plan)
- Read out data block 109 (Audi A6)
- Actuator test

During the actuator test, various pump speeds are activated and evaluated by the engine control unit. The actuator test must therefore not be interrupted.

Exhaust emission treatment

Secondary air system

A further measure to ensure compliance with the EU V and ULEV II exhaust emission standards is the use of a secondary air system.

It facilitates more rapid heating of the catalytic converters and reduces exhaust emissions by injecting air into the exhaust line downstream of the exhaust valves for a defined period of time after the engine is cold-started.

The unburned hydrocarbons and carbon monoxide contained in the exhaust gas or accumulated in the catalytic converter will then react with the oxygen in the air. Due to the heat released in this process, the catalytic converter reaches its *light-off temperature** more quickly.

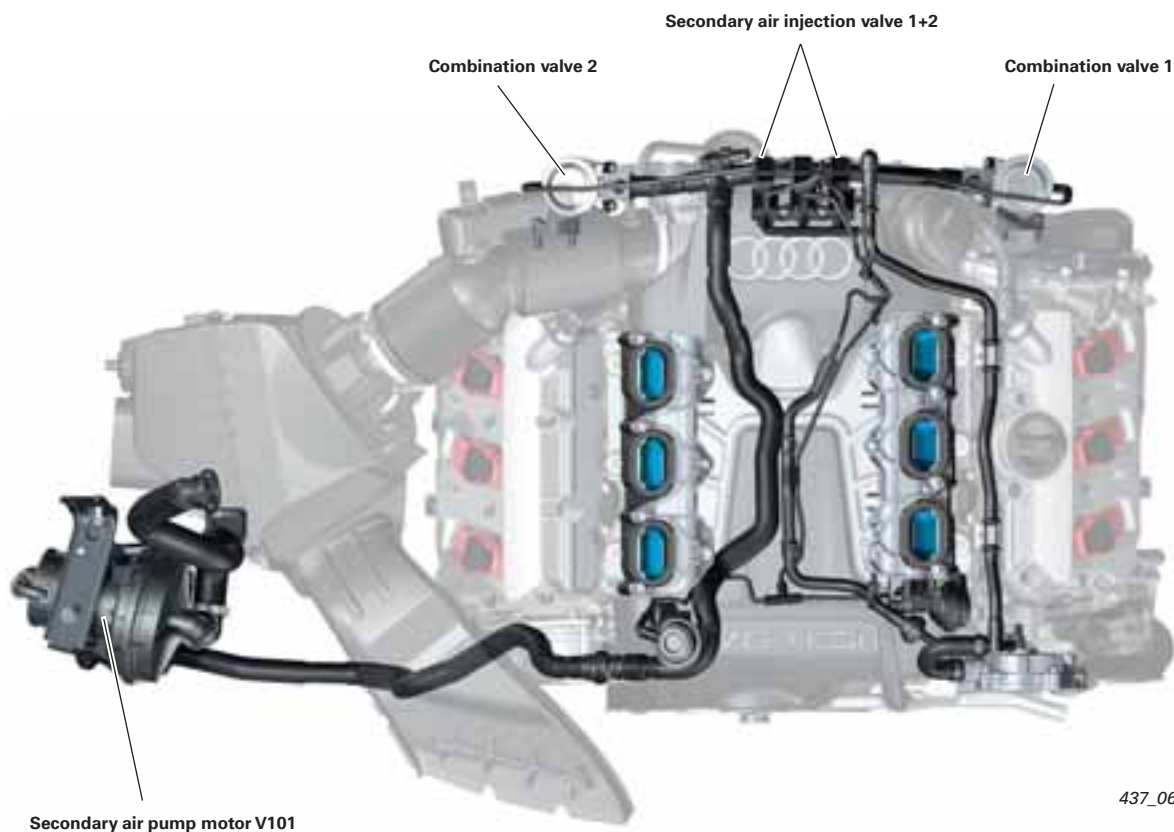

Differences to previously used systems:

- The system uses two electrical changeover valves to comply with the EU V exhaust emission standard. Previously, both combination valves were activated by a secondary air injection valve N112.
- The system used to comply with the ULEV II exhaust emission standard also has a pressure sensor - the secondary air pressure sender -1 G609. It is integrated at the branch in the secondary air line to the cylinder banks.

Reference

For a detailed description of how the system works, refer to Self-Study Programmes 207 and 217.



Secondary air injection valves

The two secondary air injection valves for activating the two combination valves are located on the back of the motor.

They turn the vacuum on and off, and for this purpose are activated electrically by the engine control unit. A partial vacuum is supplied by the mechanically driven vacuum pump.

Data bus

If the system is faulty, the stipulated exhaust emission limits can be exceeded very quickly. The limit value stipulated by the exhaust emission standard must not be exceeded by more than a factor of 1.5. For this reason, the system is subject to mandatory inspection.

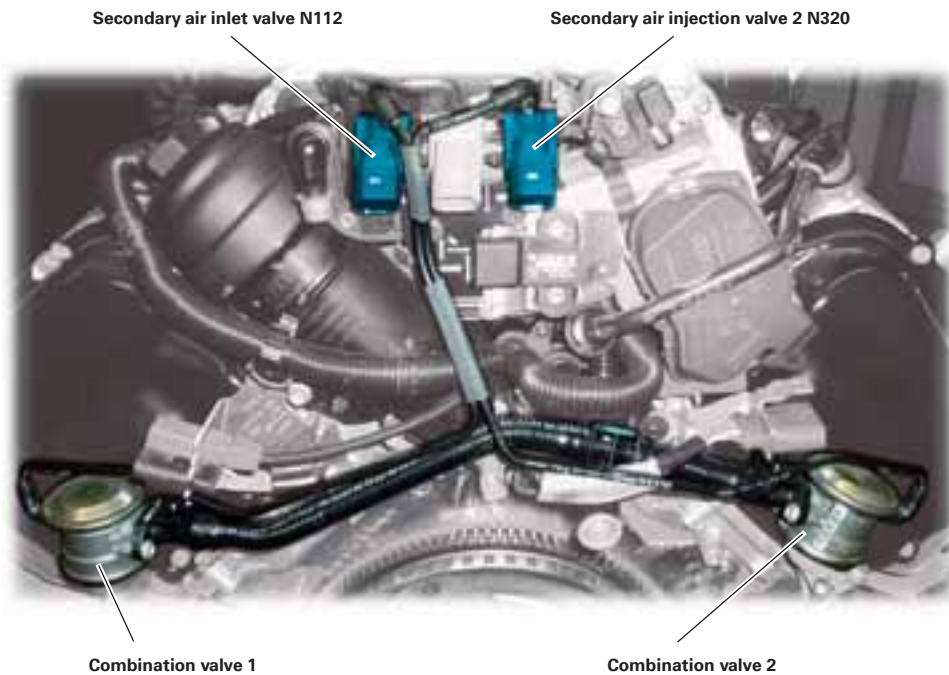

Note



The connectors and hoses of the secondary air injection valves must not be interchanged under any circumstances, as otherwise faults can occur in the system.

Testing the system on engines compliant with the EU V exhaust emission standard

The "oxygen sensor based secondary air diagnostics" function is used for testing systems on engines classified as compliant with the EU IV exhaust emission standard.

The secondary air mass is computed by the engine control unit on the basis of the changing oxygen content during the secondary air injection phase. However, this diagnosis is not made during normal secondary air operation as the oxygen sensors reach their operating temperature too late. The system is activated separately for diagnostic purposes and checked in several phases.

Measurement phase:

The secondary air pump is activated and the secondary air valves (combination valves) are opened. The engine control unit evaluates the signals generated by the oxygen sensors and compares them with the threshold values. If the threshold values are not achieved, a fault is diagnosed.

Offset phase:

After the secondary air pump is shut off, the quality of the pilot air-fuel mixture is evaluated. If the determined value deviates too much from the nominal value, the result of the secondary air diagnosis will be rejected. A faulty carburetion cycle is assumed.

Exhaust emission treatment

Testing the system on engines compliant with the ULEV exhaust emission standard (North America and South Korea)

The California Air Resource Board (CARB) requires that the secondary air system be tested during the heat-up phase of the catalytic converter. However, the oxygen sensors do not reach their operating temperature quickly enough for this purpose. This is the reason why a pressure sensor (secondary air pressure sender -1 G609) is used for making the diagnosis. The **"pressure based secondary air diagnostics"** function is used.

In this system the signal from G609 is evaluated in the engine control unit. The injected air quantity is determined from the pressure level. Restricted flow, e.g. ingress of dirt into the system downstream of the pressure sensor, causes the pressure level to increase. Restricted flow upstream of the pressure sensor or a leak in the system will cause the pressure level to decrease.

The pressure based secondary air diagnosis process (see figure)

Phase 0

The control unit is initialised at "ignition On". The signal from the secondary air pressure sender -1 G609 is saved and compared with the signals generated by the ambient pressure sensor and the intake manifold pressure sensor.

Phase 1

When the secondary air mass is injected, the pressure in the secondary air system also increases (to approx. 90 mbar). The rise in pressure is determined by secondary air pressure sender -1 G609. The analogue signal generated by G609 is evaluated by the engine control unit. If it exceeds the set limit value, for example due to a blockage in the system or a leak, a fault entry will be generated. If a fault repeats itself, the engine electronics warning lamp will be activated. If no fault occurs during phase 1, the diagnostic process is continued.

Phases 2.1 and 2.2

During these two phases, a secondary air valve (combination valve) is opened and the other valve closed alternately for a short period of time. The determined values are compared with the value saved in phase 0. Blockages or leaks can thus be determined for each cylinder bank. Even leaks downstream of the combination valves can be identified from the pressure amplitudes.

Phase 2

During this phase, both combination valves are closed and checked for leaks. The value determined by the secondary air pressure sender -1 G609 is evaluated for this purpose.

Phase 3

The secondary air pump is shut off and both combination valves are closed. The difference between the actual measured pressure and the stored value determined in phase 0 is evaluated. A faulty secondary air pump (does not shut off) or faulty secondary air pressure sender -1- G609 can thus be detected.

Phases of the secondary air diagnosis process

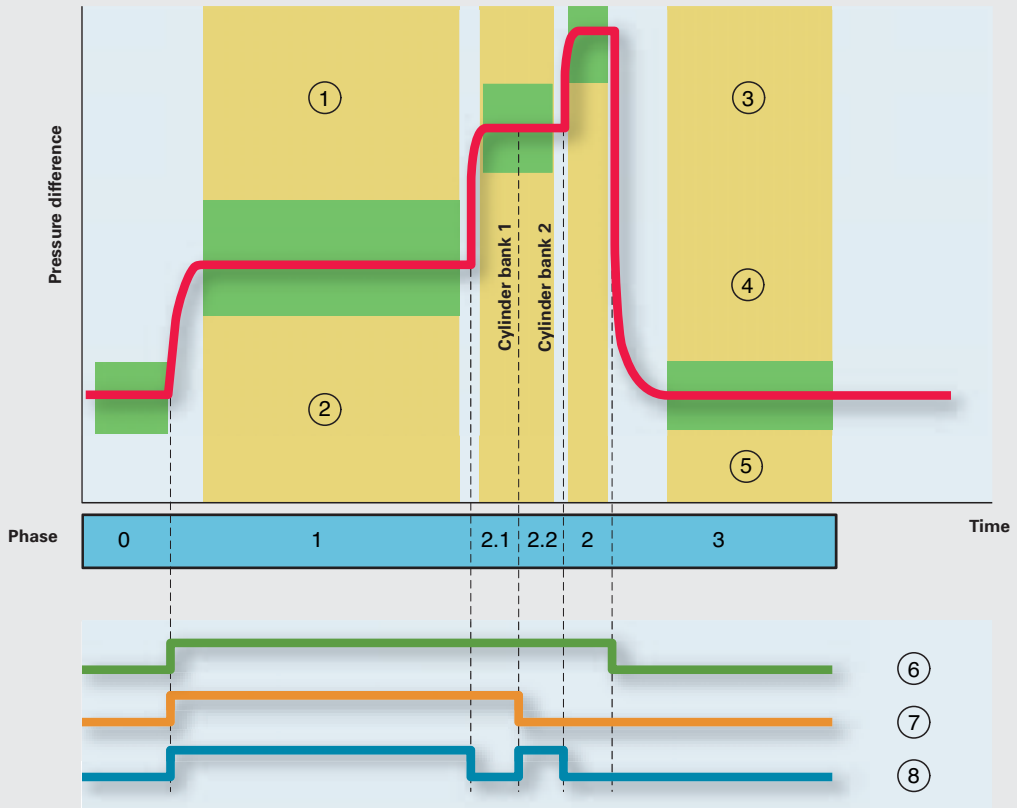

- ① Blockage (restricted flow)
- ② Reduced pumping capacity or a blockage upstream of secondary air pressure sender -1 G609
- ③ Secondary air pump running (does not shut off)
- ④ Faulty pressure sensor
- ⑤ Faulty pressure sensor
- ⑥ Secondary air pump running
- ⑦ Combination valve 1 open
- ⑧ Combination valve 2 open

Fuel system

Overview

Like the 3.2l V6 FSI engine with Audi valvelift system, the 3.0l V6 TFSI engine uses a supply-on-demand fuel system.

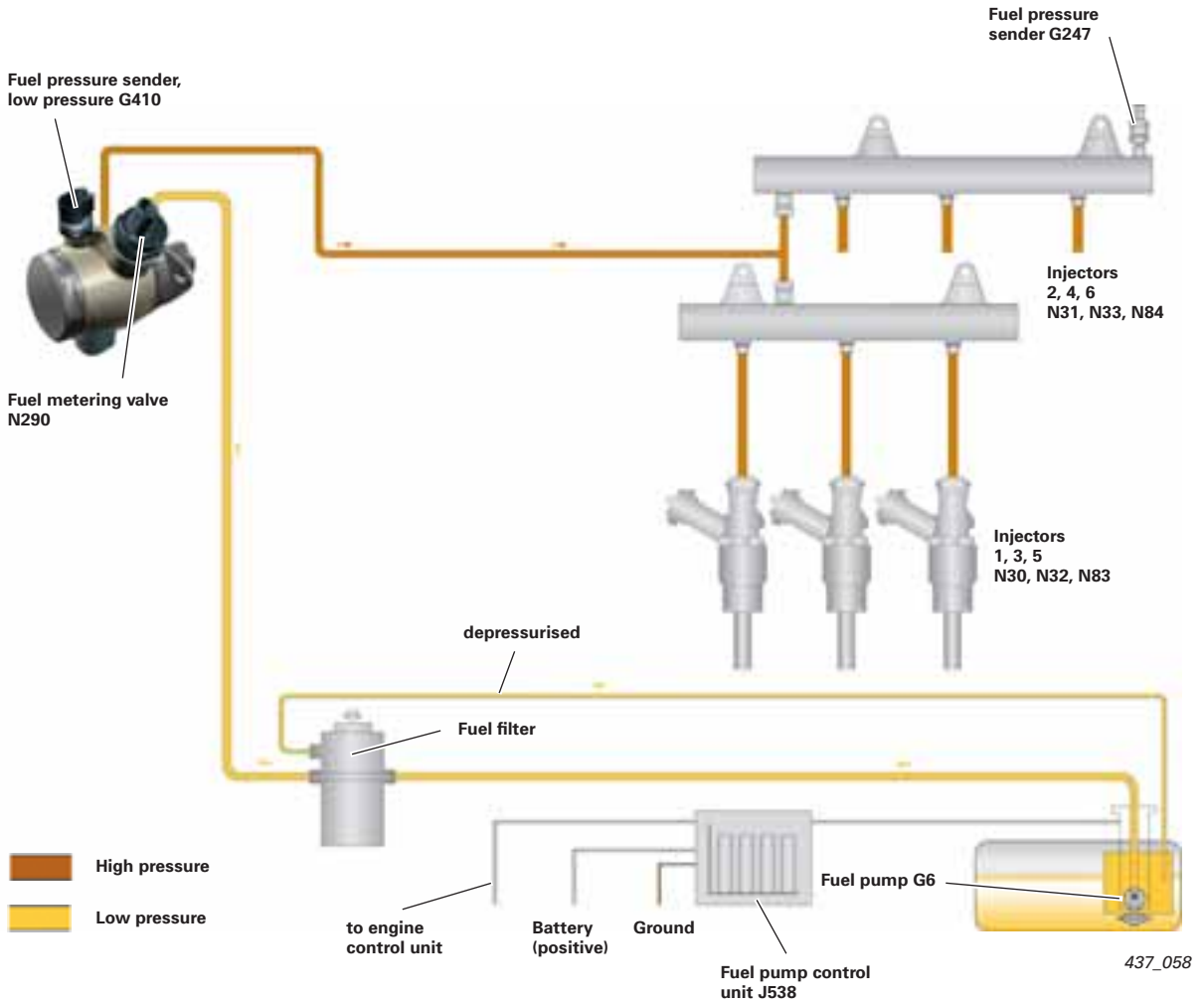

High-pressure fuel pump

A 3rd generation pump is used as the fuel pump. The high-pressure fuel pump is manufactured by Hitachi.



Reference

For information on the fuel system, please refer to Self-Study Programme 432, "Audi 1.4l TFSI engine".



437_059

Injectors

The injectors developed in conjunction with Continental (formerly Siemens VDO) represent a further advancement.

The six-hole nozzles were designed to ensure optimal homogenisation of the fuel-air mixture in any operating state of the engine.

The flow rate has also been significantly increased to reduce the duration of the injection cycle (less than 4 milliseconds at full throttle).

The injection time window can therefore be configured so that the injection timing is neither very early (fuel deposition on piston) nor very late (short mixture formation time until ignition).

The new injectors are a key factor:

- Reduction of hydrocarbon emission
- Increased rate of combustion
- Reduced tendency to knock

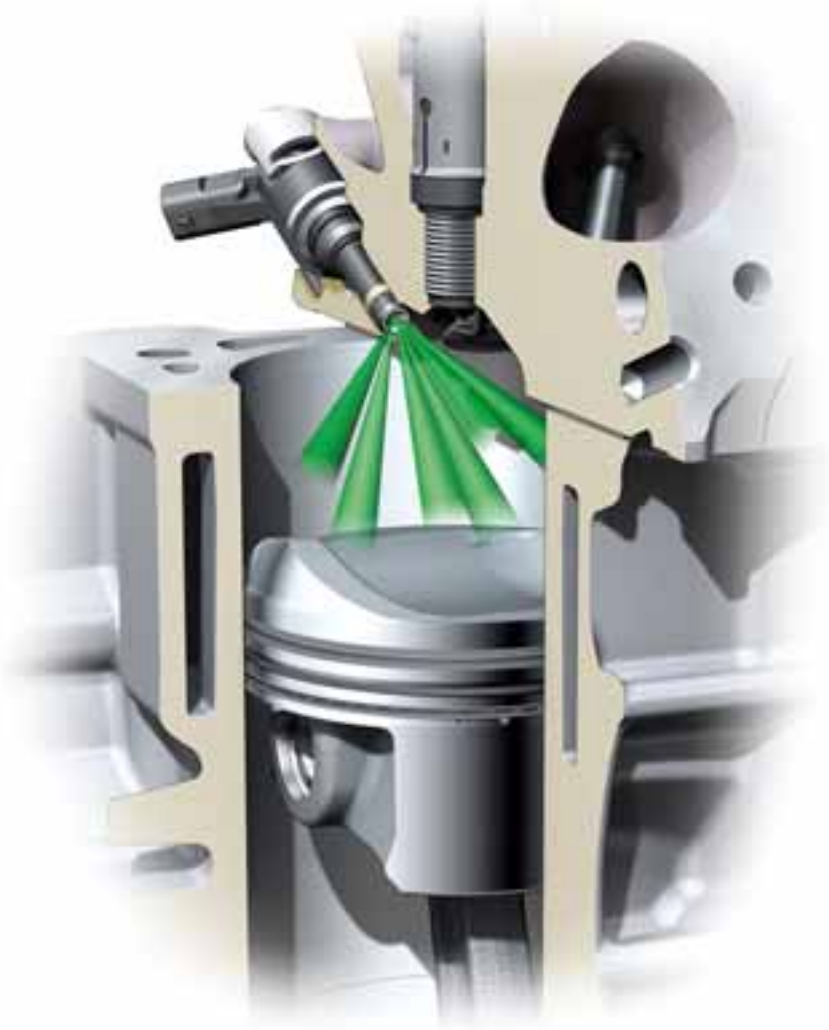

437_024

Engine management

System overview (Audi A6 of model year 2009)

Sensors

Charge pressure sender G31, G447
Intake manifold pressure sender G72, G430

Intake manifold pressure sender G71
intake air temperature sensor G42

Secondary air pressure sender -1 G609
(for ULEV vehicles only)

Engine speed sender G28

Throttle valve control unit J338
Angle sender G188, G187

Control flap control unit J808
Control flap potentiometer G584

Hall sender G40 (intake, bank 1)
Hall sender 2 G163 (intake, bank 2)
Hall sender 3 G300 (exhaust, bank 1)
Hall sender 4 G301 (exhaust, bank 2)

Accelerator pedal position sender G79
Accelerator pedal position sender 2 G185
Clutch position sender G476

Brake light switch F

Fuel pressure sender G247
Fuel pressure sender, low pressure G410

Knock sensor G61 (bank 1)
Knock sensor G66 (bank 2)

Fuel gauge sender G
Fuel gauge sender -2- G169

Oil pressure switch F22

Oil pressure switch for reduced oil pressure F378

Coolant temperature sender G62

Intake manifold flap potentiometer G336 (bank 1)
Intake manifold flap potentiometer 2 G512 (bank 2)

Oxygen sensor before catalytic converter G39 (bank 1),
G108 (bank 2)
Oxygen sensor after catalytic converter G130 (bank 1),
G131 (bank 2)

Auxiliary signals:

J393 Door contact signal

E45 Cruise control system (On/Off)

J364 Preheater (87b)

J695 Output start relay terminal 50 stage 2

J53 Output start relay terminal 50 stage 1

J518 Start command

J518 Terminal 50 at starter

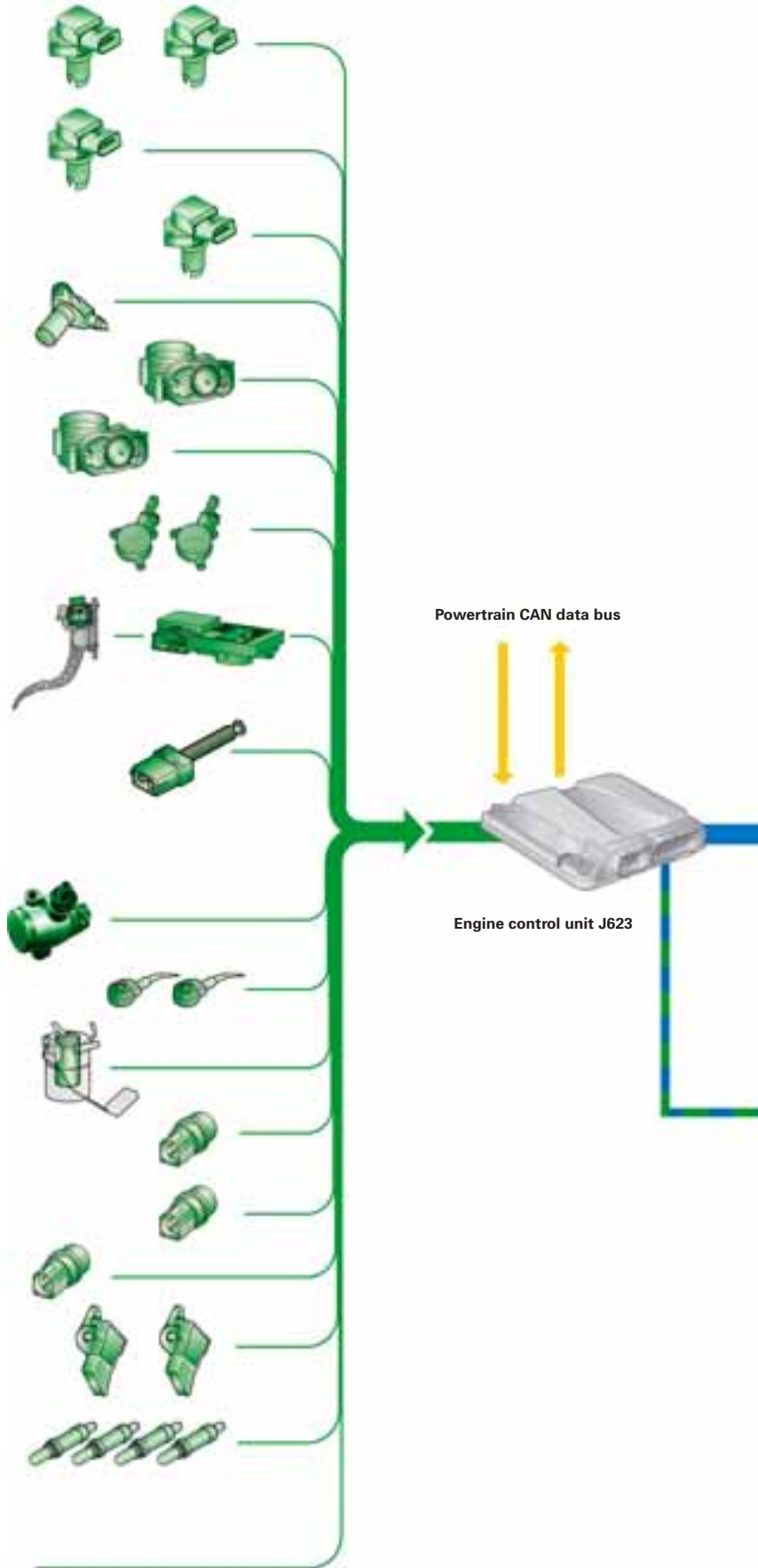



Output signals:
Engine speed to automatic
gearbox control unit J217
(vehicles with automatic
gearbox 01J only)

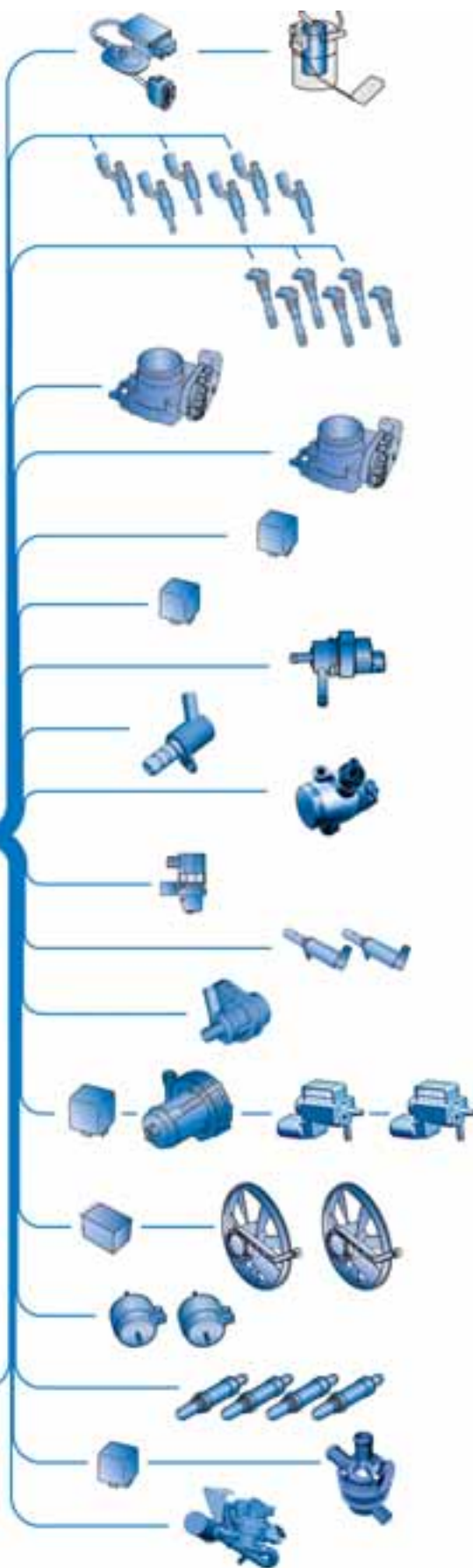

Actuators

- Fuel pump control unit J538
Fuel pump (pre-supply pump) G6

- Injectors for cylinders 1 – 6
N30 – 33 and N83, N84

- Ignition coils for cylinders 1 – 6
N70, N127, N291, N292, N323, N324

- Throttle valve control unit J338
Throttle-valve drive G186

- Control flap control unit J808
Control flap adjustment servomotor V380

- Engine component current supply relay J757

- Motronic current supply relay J271

- Activated charcoal filter solenoid valve 1 N80

- Oil pressure regulating valve N428

- Fuel metering valve N290

- Intake manifold flap valve N316

- Intake camshaft timing adjustment valve 1+2 N205
(intake, bank 1), N208 (intake, bank 2)

- Intercooling pump V188

- Secondary air pump relay J299
Secondary air pump motor V101
Secondary air injection valve 1+2 N112, N320

- Radiator fan control unit J293
Radiator fan V7
Radiator fan 2 V177

- Electro/hydraulic engine mounting solenoid
valves N144, N145

- Lambda probe heater Z19, Z28, Z29, Z30

- Auxiliary coolant pump relay J496
Coolant run-on pump V51

- Fuel system diagnostic pump V144
(vehicles with fuel system diagnostic pump)

Engine control unit

The latest generation of engine control unit is used in conjunction with this engine unit. The Simos 8 engine control unit is a joint development of Audi and Continental (formerly Siemens VDO).

During the development process, special emphasis was placed on throttle-free load regulation (refer to "Load regulation").



437_056

Operating modes

The FSI injection process is configured for homogeneous mixture formation. The complete fuel charge is injected into the combustion chamber during the intake phase. This does not include the engine start and warm-up phases, during which the following operating modes are used.

1. Engine start

In the start phase of the engine, a **high-pressure stratified start** mode is implemented. For this purpose, the fuel pressure is increased to 45 – 100 bar. The fuel pressure level is dependent on the engine temperature. At low temperatures, the fuel pressure is higher.

High-pressure stratified starting takes place at coolant temperatures between -24 °C and at operating temperature (90 °C).

At coolant temperatures below -24 °C, starting takes place at low pressure to protect the components. The pressure is identical to the pressure in the electrical fuel pump in the fuel tank.

2. Cold start/warm-up phase

During this phase, a dual injection or homogeneous split (HOSP) mode is used.

The total quantity of fuel to be injected is divided into two partial quantities and injected into the combustion chamber at different times. The injection time window is before and after the bottom dead centre position of the piston. By the second injection, the intake valves are already closed.

HOSP mode is used in two applications:

- The first application is the "cold start" and is always used. It serves to heat up the catalytic converters and takes place at coolant temperatures between -7 °C and 45 °C.
- The second application is the "warm-up", which is only used under heavy engine load when the driver requests a high engine output. It serves to optimise engine load and speed, but also to reduce soot emission. The temperature range for this application is between -20 °C and 45 °C. In this case, the second injection is later than during the cold start phase.

Maintenance work

Maintenance work	Interval
Engine oil replacement interval with LongLife oil: Engine oil specifications:	up to a maximum of 30,000 km or 24 months depending on SID ¹⁾ (oil change interval is dependent on driving behaviour) Engine oil to VW standard 50 400
Engine oil replacement interval without LongLife oil: Engine oil specifications:	Fixed interval of 15,000 km or 12 months (whichever comes first) Engine oil to VW standard 50 400 or 50 200
Engine oil filter replacement interval:	at every oil change
Engine oil change quantity (incl. filter):	6.5 litres
Engine oil extraction/drainage:	both are possible
Air filter replacement interval:	90,000 km
Fuel filter replacement interval:	Lifetime
Spark plug replacement interval:	90,000 km or 6 years (whichever comes first)

Timing gear and ancillary units drive	
Replacement interval of the ribbed V-belt for all ancillary units except Roots blower:	Lifetime
Replacement interval of the ribbed V-belt for Roots blower:	120,000 km
Tensioning systems of both ribbed V-belts:	Lifetime
Timing gear chain replacement interval:	Lifetime
Timing gear chain tensioning system:	Lifetime

¹⁾ SID = Service Interval Display

Special tools



Here you can see the special tools for the 3.0l V6 TFSI engine with Roots blower.

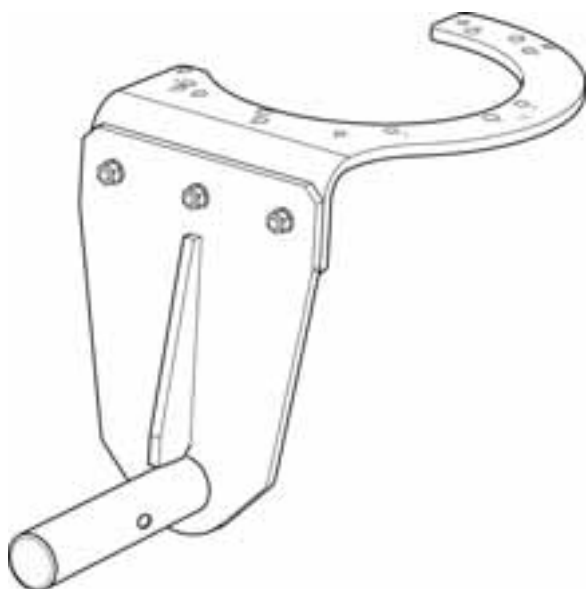

437_063

T40206/1 Gearbox support plate

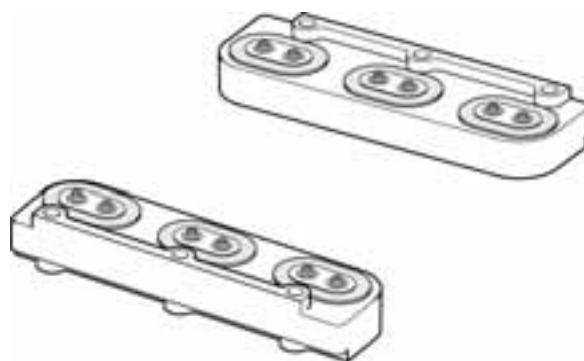

437_075

T40206/2 Mount for supercharger module

Glossary

This glossary explains to you all terms written in italics or indicated by an asterisk (*) in this Self-Study Programme.

Blow-by gases

Blow-by gases are also known as leakage gases. When the engine running, blow-by gases flow from the combustion chamber and past the piston into the crankcase. This is due to the high pressure inside the combustion chamber and the absolutely normal leakage that occurs around the piston rings. Blow-by gases are extracted from the crankcase by the PCV system and admitted into the combustion chamber.

Cracked con-rod

This name derives from the manufacturing process. In this process the con-rod shaft and the big end bearing cover are separated from one another by breaking (cracking) them at a pre-determined point. The advantage of this process is that the finished parts fit one another perfectly.

EMC

This abbreviation stands for Electromagnetic Compatibility. It is defined as the ability of equipment electrical and electronic equipment to operate effectively in close proximity without causing mutual interference through unwanted electrical or electromagnetic effects.

Hall sender

The Hall sender (also known as Hall sensor or Hall probe) utilises the Hall effect to measure magnetic fields and currents, and for position sensing. If a Hall sensor is energised with electrical current and placed into a vertical magnetic field, it will supply an output voltage proportional to the product of the magnetic field strength and the electrical current.

Helmholtz resonator

A Helmholtz resonator is an acoustic resonator designed to reduce intake noise. It consists of an air space with a narrow opening to the exterior. The Helmholtz resonator was named after the German physicist Hermann von Helmholtz.

Light-off temperature

The temperature at which the conversion rate of the catalytic converter is 50 %. The light-off temperature is highly relevant to future and US exhaust emission standards, as they stipulate low emissions even when the engine is cold.

PWM signal

The abbreviation PWM stands for Pulse Width Modulated signal. A PWM signal is a digital signal where one variable (e.g. electrical current) alternates between two values.

The length of the interval between this change-over varies depending on activation level. In this way, it is possible to transmit digital signals.

Split-pin design

Depending on engine type, the crank pin has an offset (also referred to as split pin") due to the V angle or cylinder bank angle. This configuration is necessary to achieve a uniform firing interval.

Valve timing

The term "valve timing" is used to describe the periods during which the valves of an engine are opened or closed. If the angular ranges of the valves are transferred to a pie chart, the result will be the timing diagram of an engine.

Viscosity

An important physical property of liquids is their viscosity. Viscosity is temperature dependent and is a measure of how "thick" a liquid is at different temperatures. The viscosity of oils is specified as a viscosity index.

This index describes the flow behaviour of an oil at different temperatures.

Test yourself

Which of the following answers is correct?

Sometimes only one answer can be chosen.

At other times, more than one answer may be correct – or all of them!

1. Why is a Roots blower based charging system used on the 3.0l V6 TFSI engine?

- A The engine achieves good starting performance and has a wide range of characteristics from comfort-oriented to ultra-sporty.
- B Thanks to the characteristic resulting from supercharging, the engine is suitable for use in multiple models (ranging from the Audi A4 to the A8).
- C Forthcoming exhaust emission standards cannot be met by using an exhaust turbocharger.

2. What are the advantages of a Roots blower over an exhaust turbocharger?

- A Low cost of manufacture and low weight.
- B The compressed air paths to the cylinders are very short, resulting in extremely quick response.
- C Better exhaust emission characteristics because the catalytic converter reaches its operating temperature more quickly.

3. Why is a bypass valve located in the supercharger module?

- A To increase charge pressure when high output is requested.
- B It eliminates the need for complex shut-off of the Roots blower belt drive.
- C To regulate the charge pressure.

4. Please identify the component parts of the Roots blower!



437_064

- 1
- 2
- 3
- 4
- 5

1. A, B;
 2. B, C;
 3. B, C;
 4. 1 = damping plate, 2 = main throttle valve,
 3 = bypass valve, 4 = rotors, 5 = intercooler

Solutions:

From the glorious 1930s tradition of motor sport dominated by cars bearing the four-ring badge, the Roots blower is now staging a comeback. The new 3.0l TFSI engine is not only powerful, extremely quick and ultra-efficient. It is also the new top version in Audi's V6 engine range, and sets impressive benchmarks for fuel economy and clean emissions. The engine is notable for its sporty throttle response, exceptional agility and "bite". It revs up to its 6,500 rpm maximum with playful ease, achieving its rated output of 213 kW (290 bhp) at just under 5,000 rpm.

All this has been achieved thanks to an array of refined high-tech features.

The crankcase has been adapted to the higher prevailing pressures, and all components have been systematically optimised for minimal friction. Both intake camshafts can be adjusted through 42° crankshaft angle. In the intake ports, tumble flaps induce a tumbling movement in the incoming air to optimise mixture formation.

The improved fuel system with its new six-hole nozzles will allow up to three injections per working cycle in future. The engine's high compression ratio of 10.5:1 is also a major factor in enhancing efficiency. The direct injection principle is once again the key, because the intensively swirled fuel cools the combustion chamber, reducing the tendency to knock. Inside the Roots blower, two four-vane rotary pistons counter-rotate at a speed of up to 23,000 rpm, delivering 1,000 kg of air per hour and forcing it into the combustion chambers at a boost pressure of up to 0.8 bar. Two water-to-air intercoolers integrated in the supercharger module enhanced efficiency still further. An extensive package of measures reduces the level of noise generated by the Roots blower to a minimum.

The new 3.0l TFSI engine will achieve an average fuel consumption of well under 10 litres per 100 km in virtually all longitudinally engined Audi models, for which it had been earmarked. As with all Audi innovations, the engine fully embraces the principle of "Vorsprung durch Technik".

Self-Study Programmes

In this Self-Study Programme you will find all you need to know about this engine presented in a summarised form. For more information on the subsystems mentioned in this document, please refer to the relevant Self-Study Programmes.



437_060



437_061



437_062



437_065

SSP 411 Audi 2.8l and 3.2l FSI Engines with Audi Valvelift System

SSP 432 Audi 1.4l TFSI Engine

SSP 325 Audi A6 '05 Engines and Transmissions

SSP 207 The Audi TT Coupé

All rights reserved. Technical specifications subject to change without notice.

Copyright
AUDI AG
I/VK-35
Service.training@audi.de
Fax +49-841/89-36367

AUDI AG
D-85045 Ingolstadt
Technical status: 10/08

Printed in Germany
A08.5S00.53.20